

Engineering 5003 - Ship Structures

Problems

Chapter 1 – General Concepts.

1. **Ship design process** Longitudinal strength is a primary concern during the design of a ship.

- Describe the steps in the ship design process (in general terms) that must occur prior to consideration of the longitudinal strength.

- What is the difference between “low frequency dynamic” and “high frequency dynamic” loads? Give examples.

2. Longitudinal strength is a primary concern during the design of a ship.

As a Naval Architect, you are asked by a potential client to explain where structural design fits within the overall design process. Provide a short (1-2 paragraph) written answer (include any sketches that you wish).

3. **Design Process** Describe the steps in the ship design process that relate to longitudinal strength. Use well-written prose, describing the process.

4. Loads on ships

The following is a table of load types. Identify each load as static, quasi-static, dynamic or transient. Place a check mark ✓ to indicate which categories apply to each load type. If more than one type applies, explain why in the comments column.

LOAD	static	quasi-static	dynamic	Transient	comments
Dry cargo					
Liquid cargo					
Engine					
Propeller					
Ice					
Waves					
Other: _____					
Other: _____					

5. Answer the following questions in the space provides (ie on 2 lines each)

a) In preliminary design, when can the preliminary structural calculations be made?

b) List 5 purposes of structure in a ship.

c) When is a load considered to be quasi-static?

Chapter 2 – Ship Structural Features.

6. Read the SSC Case Study V and name all the parts of the Rhino sketch shown below.

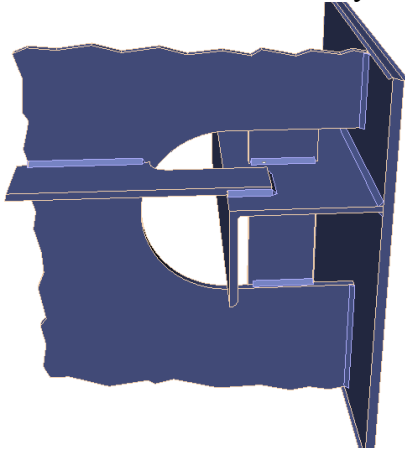

7. What was the basic cause of the “Recurring Failure of Side Longitudinal” in the SSC report?

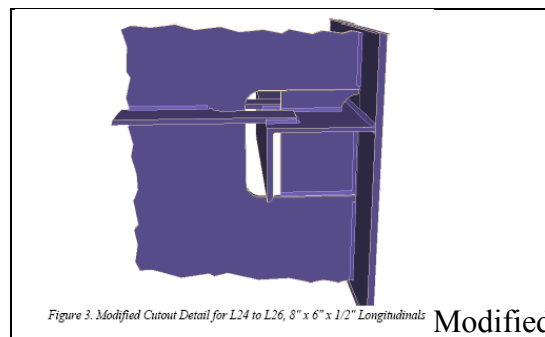
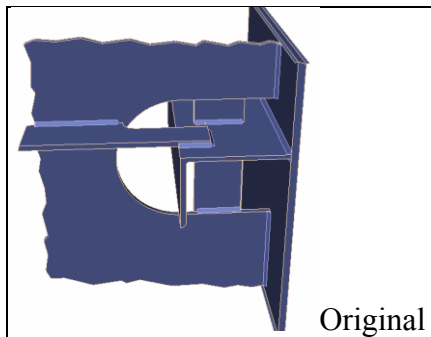

8. Sketch a X-section of a ship at mid-ships and label all features/elements.
9. Sketch, free hand, the structure in the double bottom of a ship. Keep it neat and label the elements

Chapter 3 – Strength of Materials Concepts.

10. A column is made of steel pipe with OD of 8", and ID of 7". It is 8 feet tall. The column supports a weight of 300kips (300,000 lb). How much does the column shorten under load? (E for steel is 29,000,000 psi)
11. A 2D state of stress $(\sigma_x, \sigma_y, \tau_{xy})$ is (200, -20, 45) MPa. What are the strains $(\epsilon_x, \epsilon_y, \gamma_{xy})$?
12. For a 2D state of stress $(\sigma_x, \sigma_y, \tau_{xy})$ of (180, -25, 40) MPa, plot the Mohr's circle. What are the principal stresses (σ_1, σ_2) ?
13. For a 2D state of stress $(\sigma_x, \sigma_y, \tau_{xy})$ of (100, -100, 60) MPa, what is the von-mises equivalent stresses σ_{eqv} ?

Chapter 4 – Longitudinal Strength - Buoyancy & Weight.

14. For the three station profiles shown below, draw the bonjean curves in the space provided.

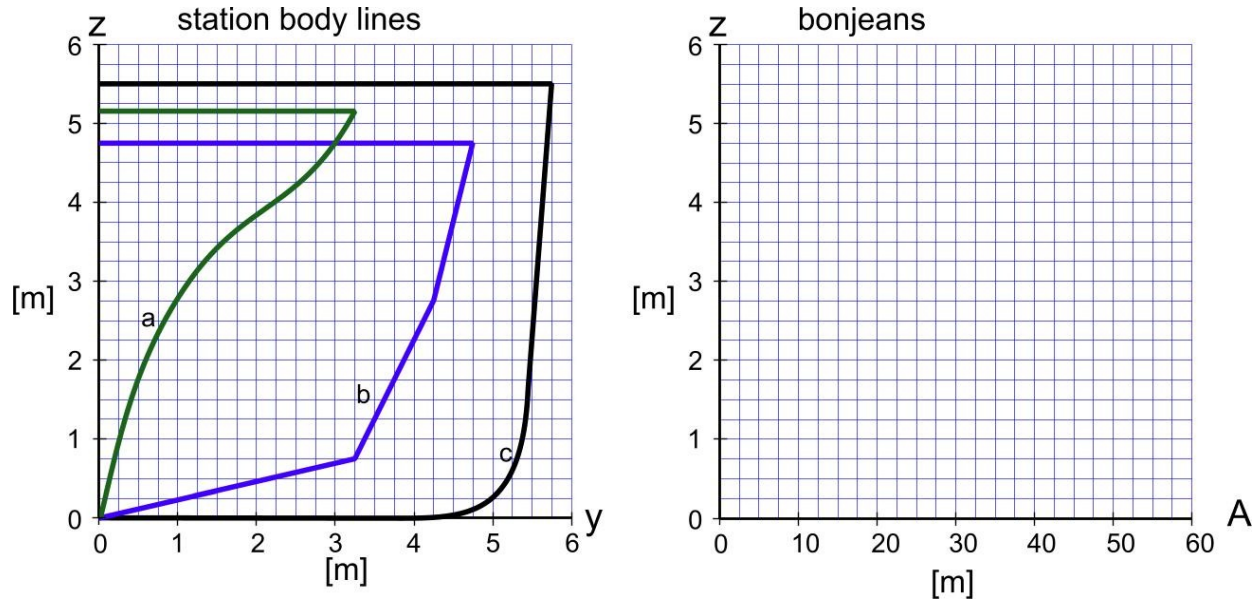

15. For a vessel with 4 stations, the bonjean curves are given at the 3 half stations. Lbp is 60m. for the vessel to float level (no trim), at a 4.5 m draft, where is the C.G.?
 What would the Prohaska distribution of weight be to achieve this? (plot)
 If the C.G is at midships, and the draft (at midships) is 4.5 m, what is the trim?

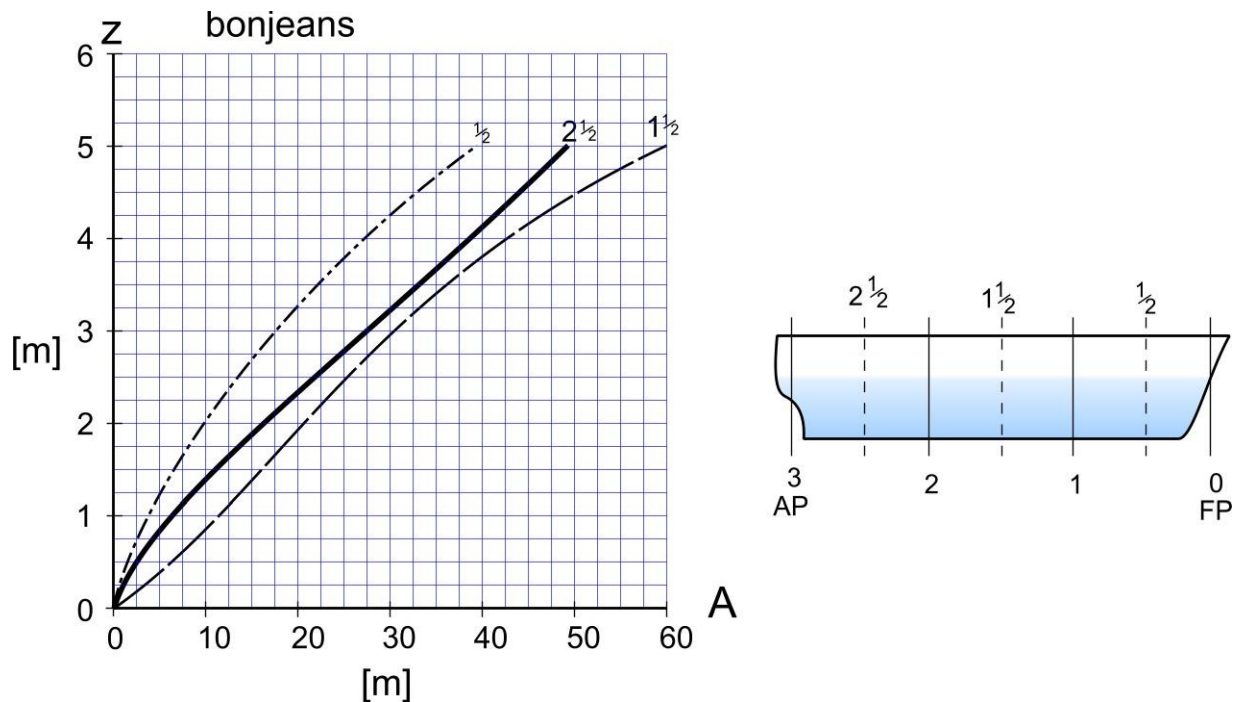

16. For the vessel body plan shown below (left), sketch the corresponding bonjean curves (on the right).

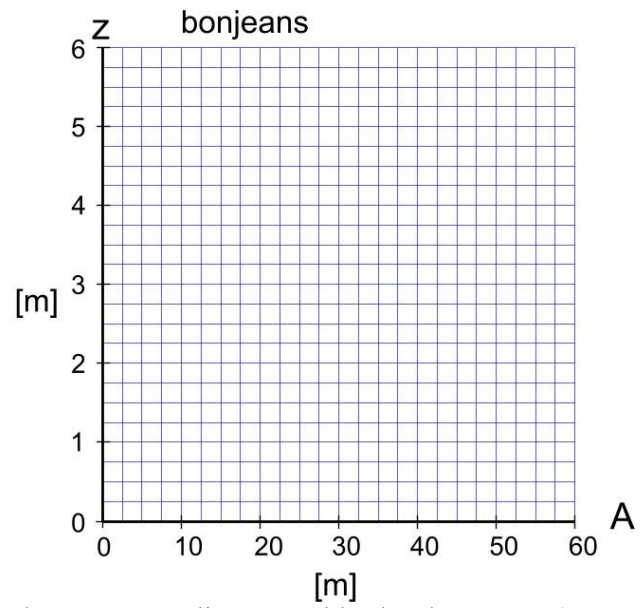
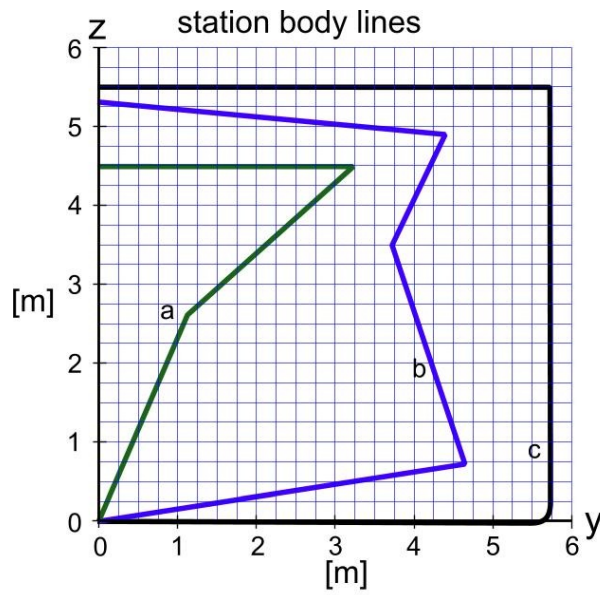

17. For the bonjean shown below (right), sketch the corresponding vessel body plan curve (on the left).

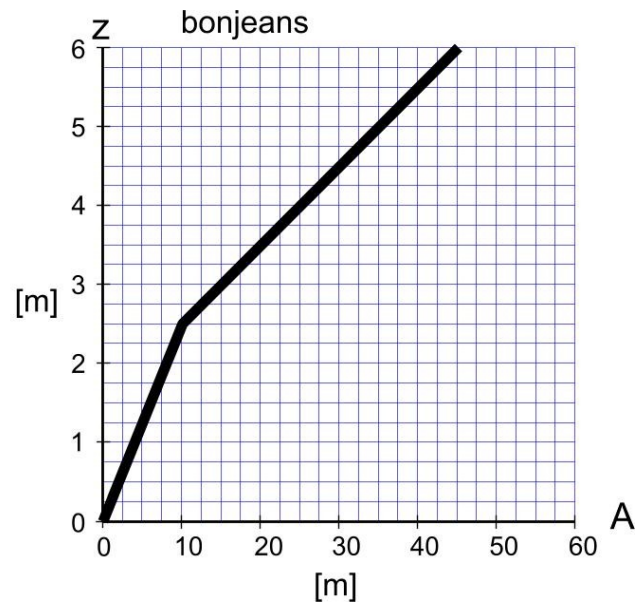
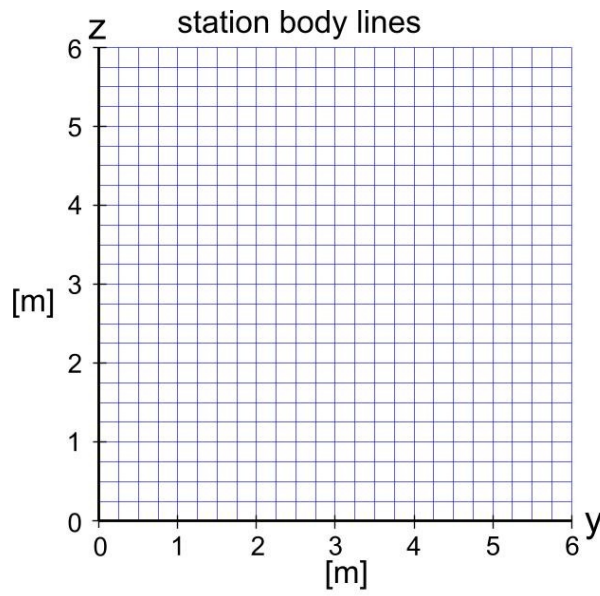

18. Bonjean Curves The following figure shows 5 potential Bonjean curves. Some of them are impossible. Identify the curves that can not be Bonjean curves and explain why. For the feasible Bonjeans, sketch the x-section that the Bonjean describes.

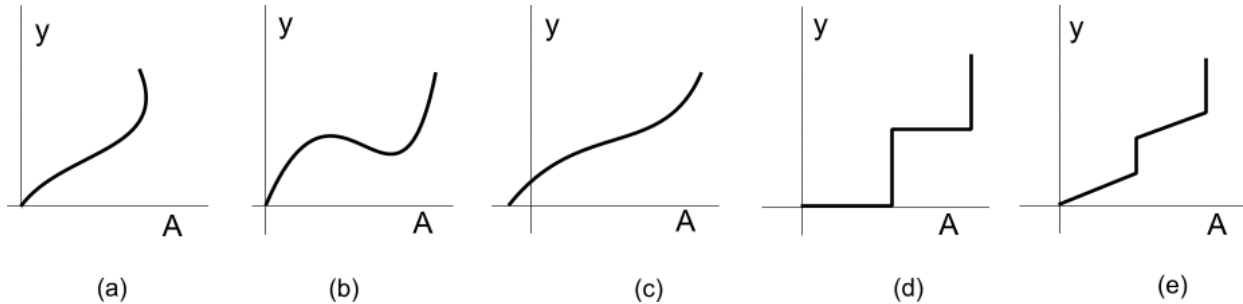

19. For the two ship stations shown below, sketch the corresponding bonjean curves on the grid below.

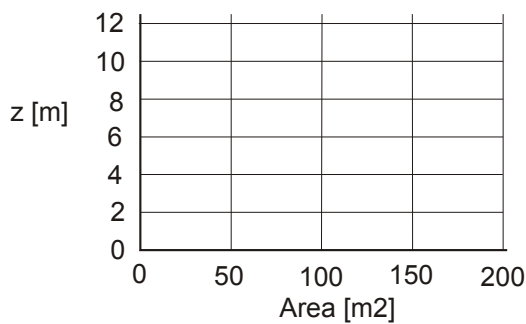
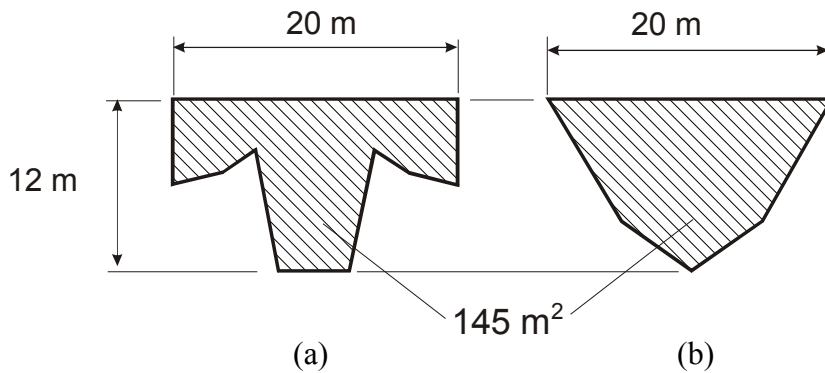

20. You are supervising a preliminary ship design project. You have asked one of your team to produce a net load (weight-buoyancy) diagram, so that bending moments can be calculated. The diagram you are given is ;

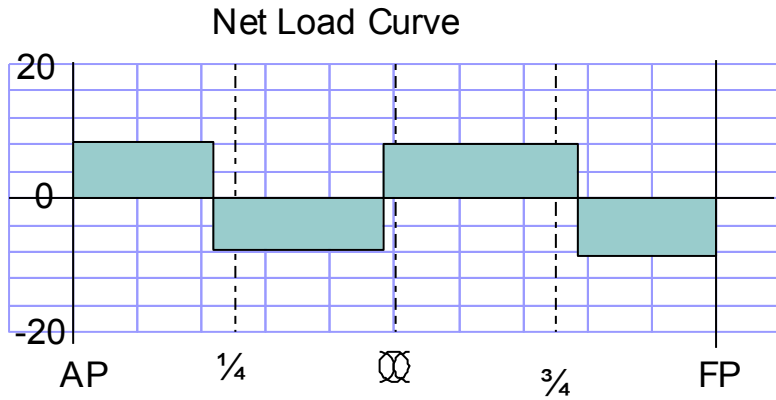

why is this diagram impossible? Justify your answer. (hint: use SFD and/or BMD)

21. For the three station profiles shown below, sketch the corresponding bonjean curves

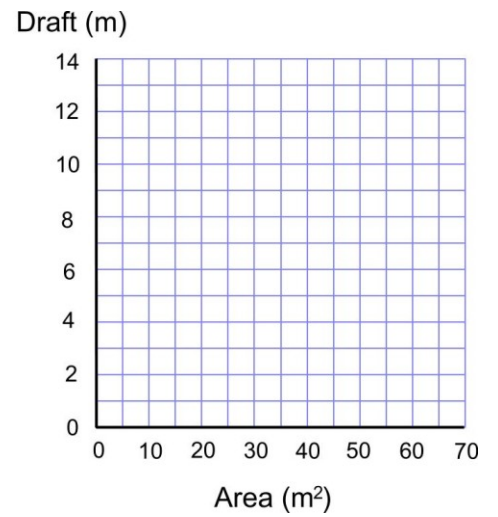
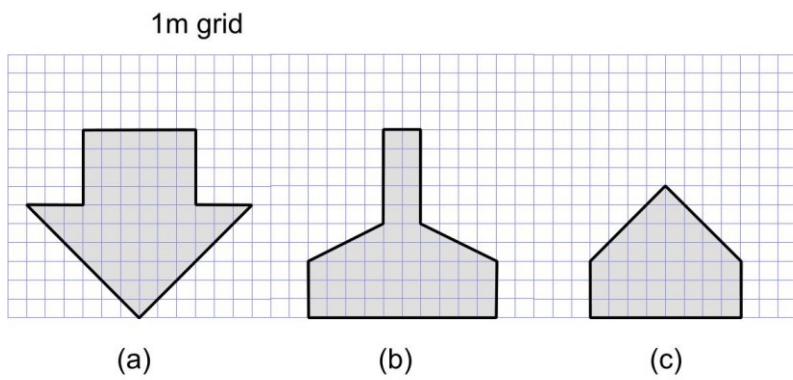

Chapter 5 – Longitudinal Strength - Still Water Moments.

22. Longitudinal strength is a primary concern during the design of a ship. Briefly explain the idea behind Murray's Method.
23. There is a 'rectangular' shaped block of wood, as shown in the image below. The block weighs 200 N and has uniform density. It is 1 m long and 0.20 m wide. It is 20 cm thick and is floating in fresh water.

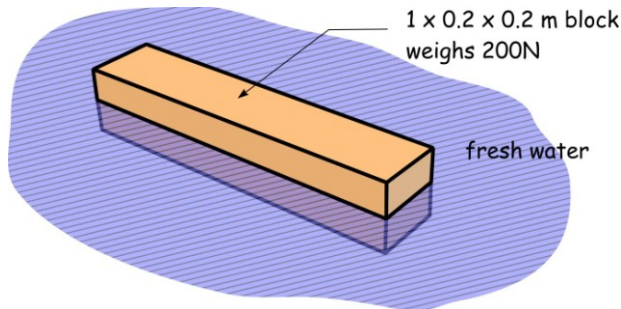

- a) draw the shear force and bending moment diagrams for the block.

Now consider the addition of a small 50 N weight on the top of the block, at a distance $2/3$ m from one end. (hint - a right triangle has its centroid at $2/3$ of its length)

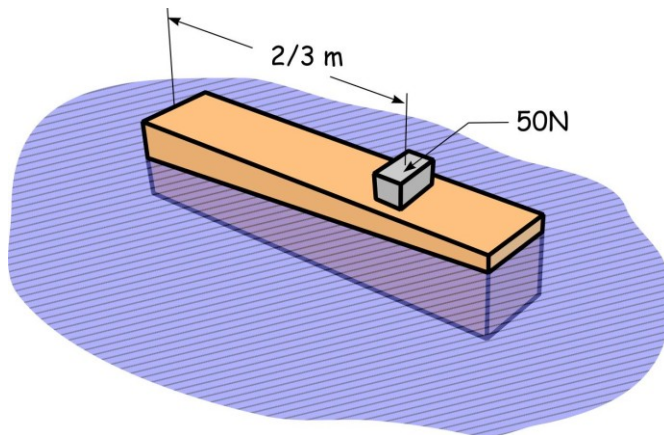

After the block settles to an equilibrium position -

- b) Draw the bending moment and shear force diagrams
- c) What is the max. bending stress on the transverse plane at the middle of the block (ie at 0.5 m from the end)?
24. There is a 'diamond' shaped block of wood, as shown in the image below. The block weighs 5.4 kg. and has uniform density. It is 60 cm long and 30 cm wide. It is 12 cm thick and is floating in fresh water. Resting on the block are 2 weights, each small blocks of steel weighing 1 kg. They are symmetrically placed and are 55cm apart. What is the midship bending moment in units of N-cm ? What is the maximum bending stress in the wooden block? Draw the bonjean curve for a cross section of the wooden block at a point 15cm from the end. (show actual units).

What is the block coefficient for the block?

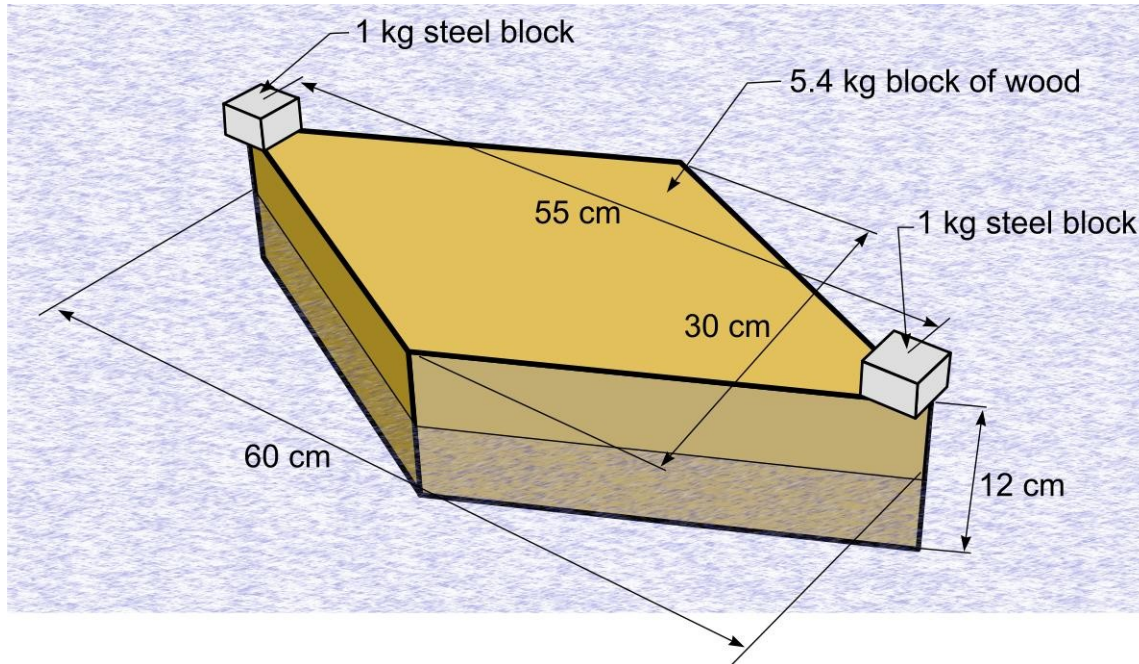

ANS: a) 171.5 N-cm (hog) b) 23.8 MPa c) Straight and then vertical d) 0.5

25. Consider a 100m vessel resting in sheltered fresh waters (see below). The CG of all weights fwd of midships is 23m fwd of midships ($f_f=23m$). The CG of all weights aft of midships is 25m aft of midships ($f_a=25m$). The weights fwd and aft are 4200 and 4600 t respectively. Two bonjean curves are given. Assume each refers to the average x-section area for 50m of ship (fore and aft). The (fore and aft) buoyancy forces act at the bonjean locations, which are 18m fwd and 20m aft (of midships). The buoyancy force aft is 4650 t.

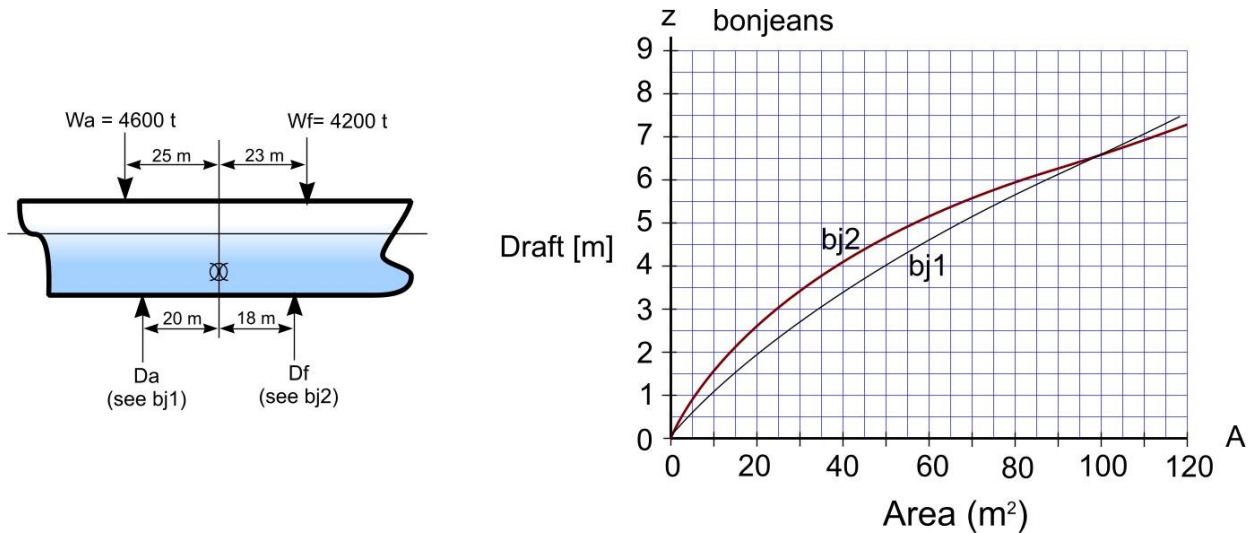

Using the bonjeans, find
 The vessel drafts at the two bonjeans.
 The buoyancy force fwd.
 The still-water bending moment at midships

26. Murray's Method Consider a 100m long vessel resting in sheltered waters. The CG of all weights fwd of midships is 20m fwd of midships ($ff=20m$). The CG of all weights aft of midships is 25m aft of midships ($fa=25m$).

- Describe how you would use Murray's Method to determine the still water bending moment for this vessel.

- What other info, if any do you need?

Note: you don't need to remember the specific values for terms suggested by Murray.

27. Hull girder strength The hull girder can be viewed as a beam. When floating in still water, is the beam statically determinate or statically indeterminate? Provide reasons for your answer.

28. You see below a sketch of a ship that is 200 m long. The displacement is made up of the lightship plus the weight of cargo in two holds. The ship has stranded itself on a submerged rock. Draw the various curves of load and response for the vessel (weight, buoyancy, net load, shear, moment, slope and deflection) that are compatible with the information given. The numerical values don't matter. The intention is to draw a set of curves that are logical for the ship as shown.

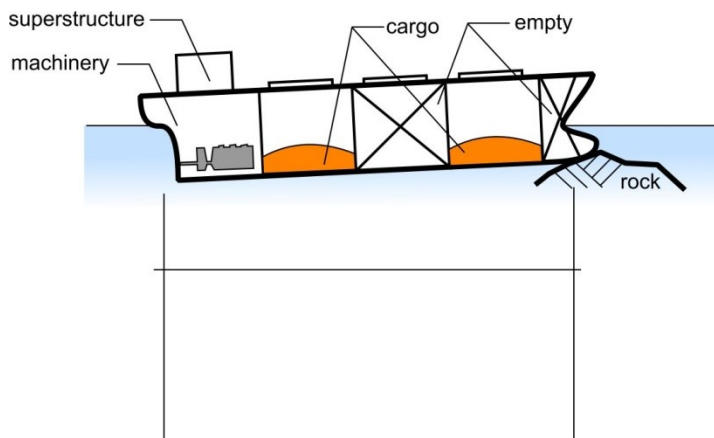

29. You see below a sketch of a ship that is 200 m long. The displacement is made up of the lightship plus the weight of cargo in two holds. The forward cargo hold is empty. Draw the various curves of load and response for the vessel (weight, buoyancy, net load, shear, moment, slope and deflection) that are compatible with the information given. The numerical values don't matter. The intention is to draw a set of curves that are logical for the ship as shown.

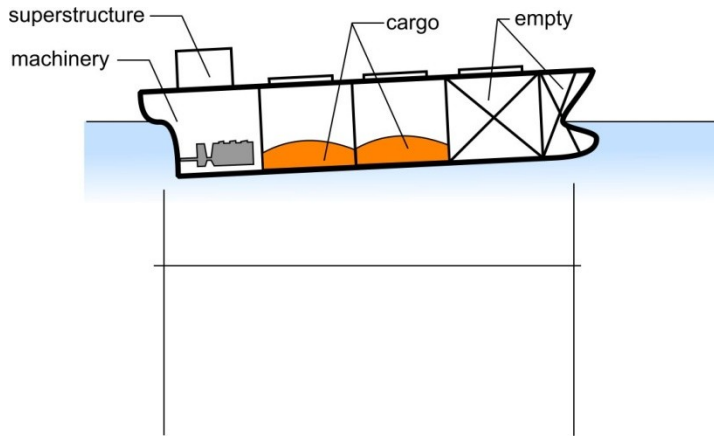

30. You see below a sketch of a ship that is 200 m long. The displacement is made up of the lightship plus the weight of ballast in 4 tanks. The cargo holds are empty. Draw the various curves of load and response for the vessel (weight, buoyancy, net load, shear, moment, slope and deflection) that are compatible with the information given. The numerical values don't matter. The intention is to draw a set of curves that are logical for the ship as shown.

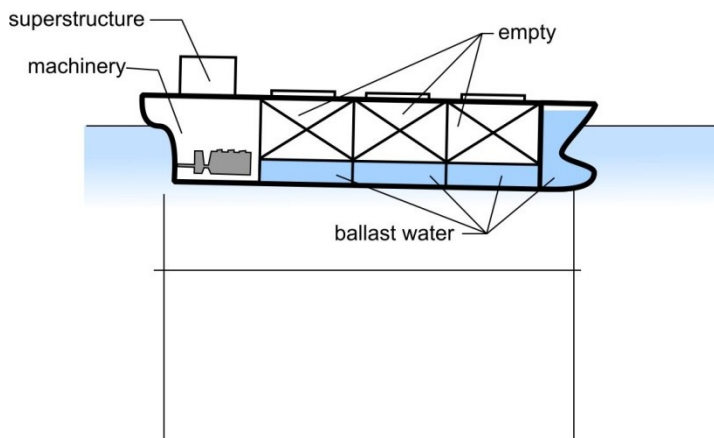

31. Calculate the still water bending moment (in N-cm) for the solid block of plastic sketched below. Assume the block has density as given and is floating in fresh water (density also given). Is the moment hogging or sagging?

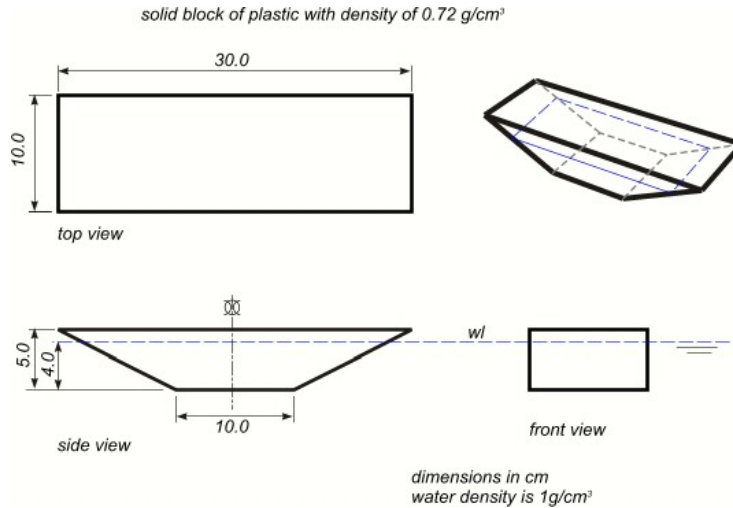

32. For the example of Murray's method in the Chapter, remove the cargo weight and add 4000 t of ballast, with a cg of 116m fwd of midship. Re-calculate the maximum sag and hog moments (both still water and wave).
33. For the example of Murray's method in the Chapter, instead of using the weight locations as given, assume that the weights are distributed according to Prohaska. Re-calculate the SWBM.
34. Consider a 100m long tanker resting on an even keel (same draft fore and aft) in sheltered waters. The CG of all weights is at midships and is 8000 tonnes. Use Murray's Method and Prohaska's values to determine the still water bending moment for this vessel (i.e. get both the weight and buoyancy BMs about midships).

Chapter 6 – Longitudinal Strength - Wave Bending Moments.

- 35.** Using a spreadsheet, plot the design trochoidal wave for a 250m vessel, for the $L/20$ wave.
- 36.** Using a spreadsheet, plot the design trochoidal wave for a 250m vessel, for the $1.1 L^{-5}$ wave.
- 37.** Self Study – examine the SW/Wave spreadsheet (circulated).

Chapter 7: Longitudinal Strength: Inclined Bending / Section Modulus

38. Find the moment of inertia of this compound section:

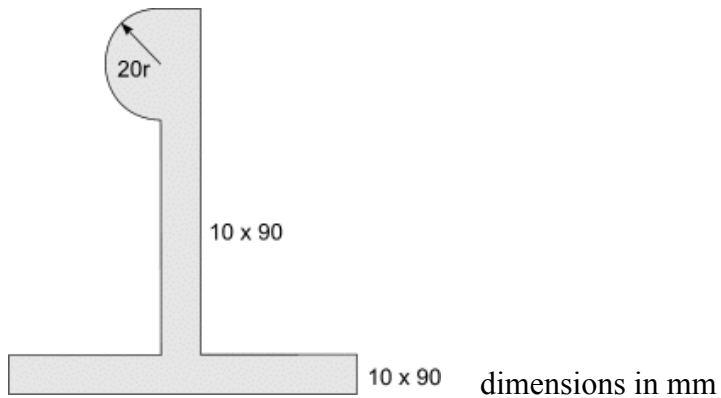

39. A box steel hull is 4m x 1m with a shell thickness of 10mm. It is inclined at 15 degrees, and subject to a vertical bending moment of 2 MN-m. Find the bending stress at the emerged deck edge.

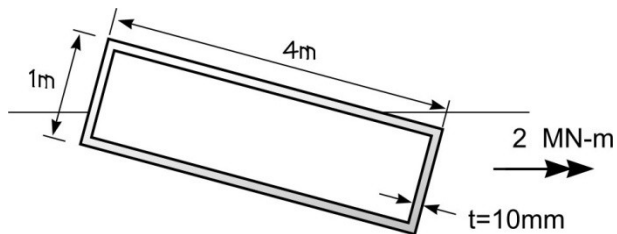

Chapter 8: Beam Theory

40. Consider a beam made of steel joined to aluminum. The steel is 10 x 10 mm, with 5 x 10 mm of Aluminum attached. $E_{\text{steel}} = 200,000 \text{ MPa}$, $E_{\text{Al}} = 80,000 \text{ MPa}$. The beam is fixed as a simple cantilever, with a length of 100mm and a vertical force at the free end of 2 kN.

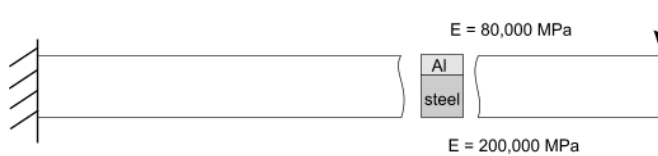

convert the section to an equivalent section in steel and calculate the equivalent moment of inertia.

What is the deflection of the end of the beam (derive from 1st principles).

What is the maximum bending stress in the Aluminum at the support?

41. For elastic beam bending, derive the equation:

$$\frac{d\theta}{dx} = \frac{M}{EI}$$

where θ is the slope of the deflected shape, M is the moment, E is Young's Modulus, I is the moment of inertia. You can assume the $\sigma = \epsilon E$ and $\sigma = My/I$. Use at least one sketch.

42. Find and draw the shear force and bending moment diagrams for the following beam. Find the values at supports and other max/min values.

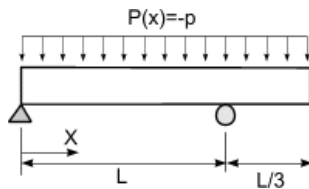

43. There is a 3m beam. The shear force diagram is sketched below.

Sketch the load, moment, slope and deflection diagrams (9)

What are the boundary conditions and discuss whether there can be more than one option for the boundary conditions.(6)

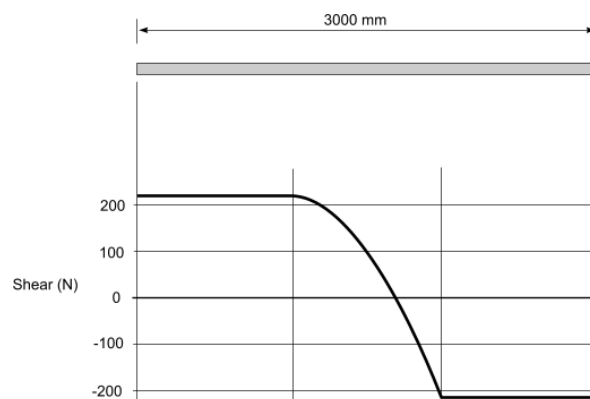

44. Consider a compound steel-aluminum beam, shown below. Calculate the deflection d (show steps)

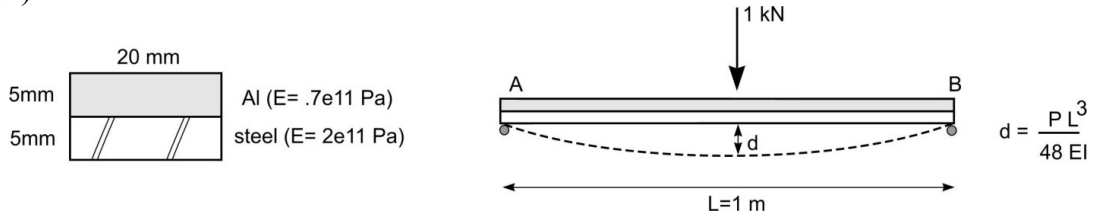

Ans: 0.112m

45. For elastic beam bending, complete Figure 1. The shear force diagram is sketched. You need to infer from the shear what the load (including support reactions) may be, as well as an estimate of the bending moment diagram, the slope diagram and the deflected shape. Draw the support conditions and the applied load on the beam, and sketch the moment, slope and deflection in the areas given.

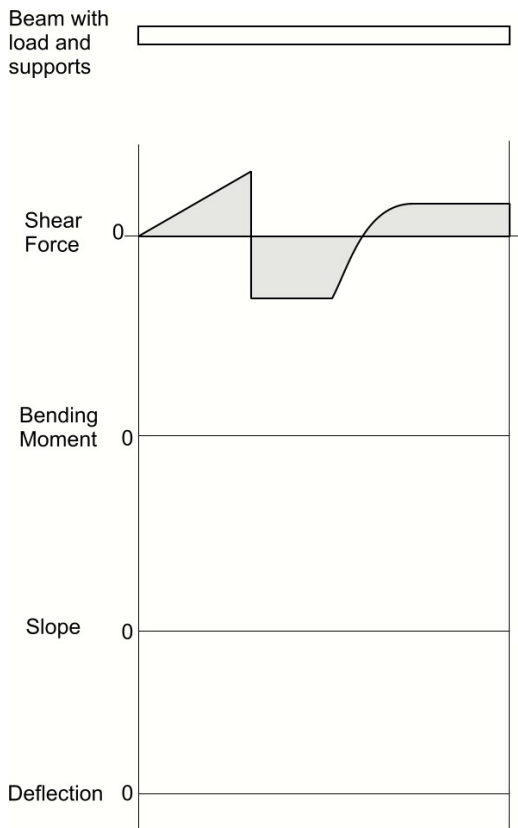

46. Beam Mechanics. For the beam sketch below:

$EI = \text{constant}$

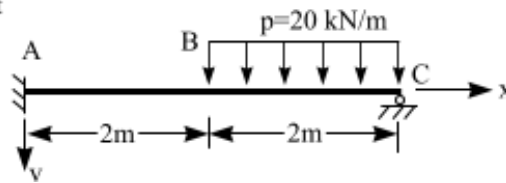

a) sketch by hand the shear, moment, slope and deflection diagrams



b) Assuming the beam is a 10cm x 10cm square steel bar, solve the problem to find the bending stress at the fixed support. Use any method you like.

47. There is a length of steel that is 3.1416 m long, 50mm wide. It has a yield strength of 500 MPa (N/mm^2), and a Young's Modulus of 200 GPa. If the steel is thin enough it can be bent into a perfect circle without yielding.

- What is the maximum thickness 't' for the steel to be bent elastically (and not yield)?
- If the steel thickness is 1mm, what is the stress when it is bent into a 1m Dia circle.
- What would the shear force diagram look like?

(Hint :this relates directly to the derivation of the differential equations for beam bending)

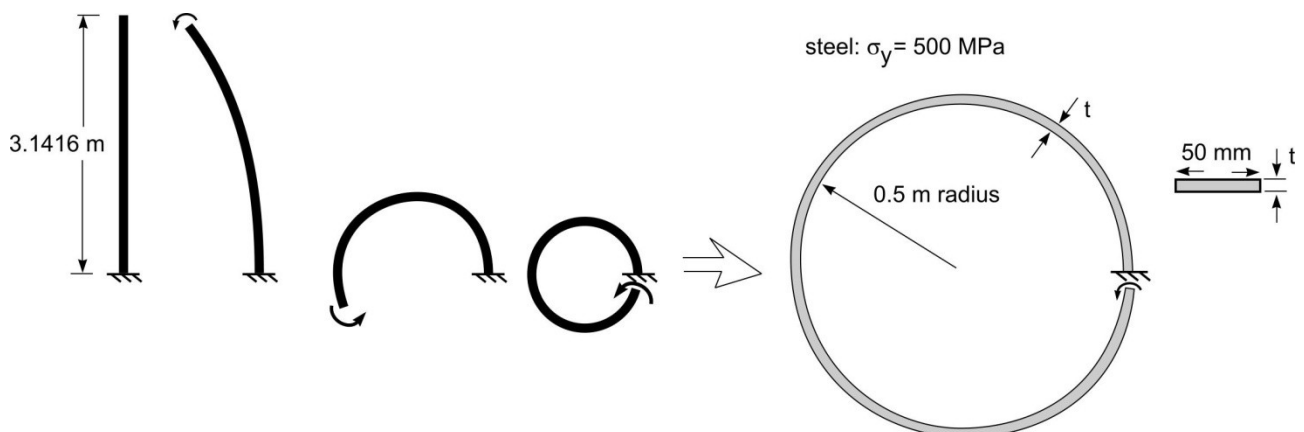

48. Sketch the shear, bending, slope and deflection patterns for the four cases shown below. No numerical values are required.

(a) symmetrical parabolic

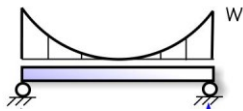

(b) ramp

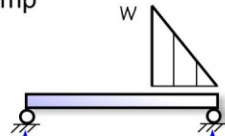

(c) point moment at center

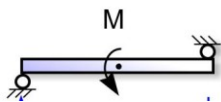

(d) inclined force off center

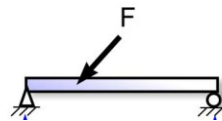

Chapter 9: Beams, Frame and Structures

49. Solve the following beam. What is the maximum deflection (mm)? What is the maximum stress (MPa) ?

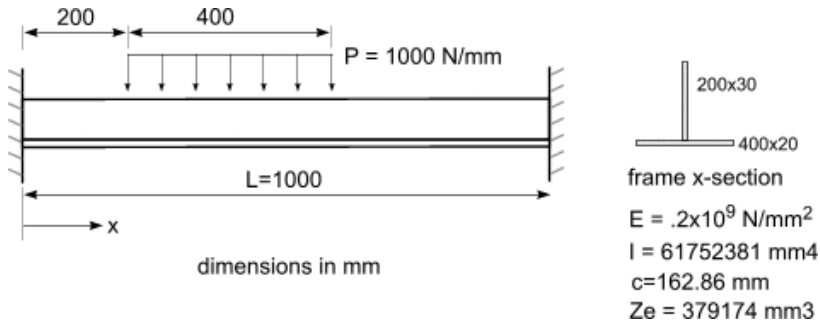

ANS: .000136mm, 140 Pa

50. Solve the following beam. What is the maximum deflection (mm)? What is the maximum stress (MPa) ?

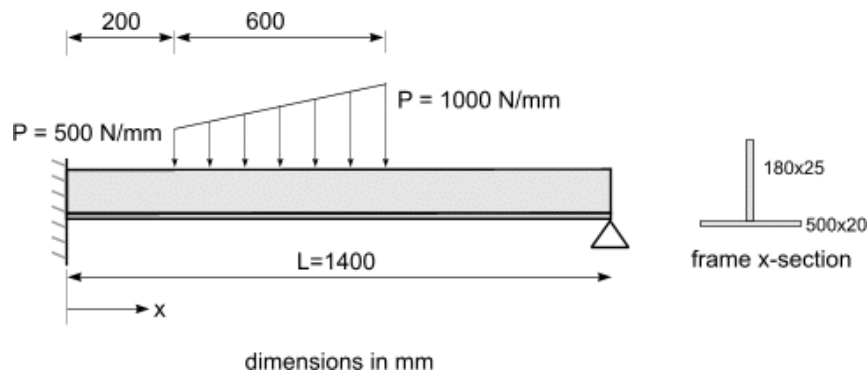

ANS: .000484mm, 253 Pa

Chapter 10: Indeterminate Beams – Force Method

51. Solve the below by removing the reaction R_B (as shown). This creates ‘cut’ problem that is a cantilever beam.

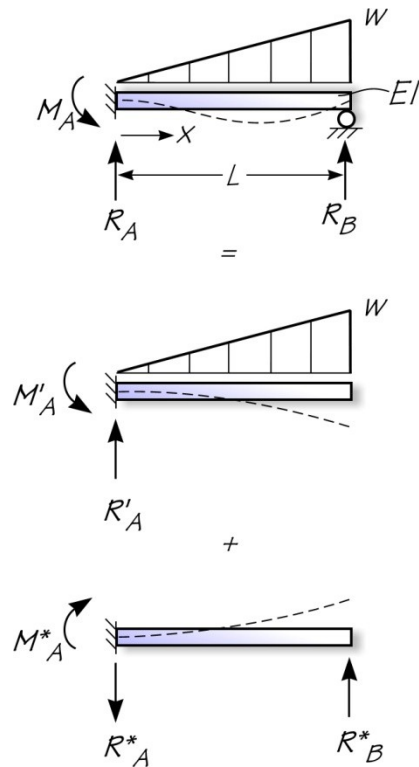

52. Force Method.

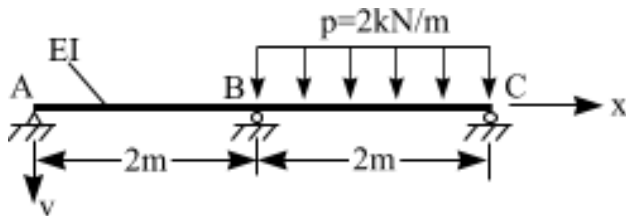

a) Sketch 3 alternative approaches to solving this indeterminate problem using the force method. For each approach, you will need two sketches of the auxiliary systems.

b) Using one of the approaches sketched in a), solve the system to find the reaction at B (in kN)

Chapter 11: Indeterminate Beams – Displacement Method

53. Solve the pinned-pinned beam by using the displacement method as sketched below. The solution for the fixed-fixed beam is the same as above. Then it is necessary to show that $M_B^* + M_B^{**} + M_B^{***} = 0$ and $M_A^* + M_A^{**} + M_A^{***} = 0$. Note: $M_A^{**} = \frac{1}{2} M_B^{**}$, and $M_B^{***} = \frac{1}{2} M_A^{***}$.

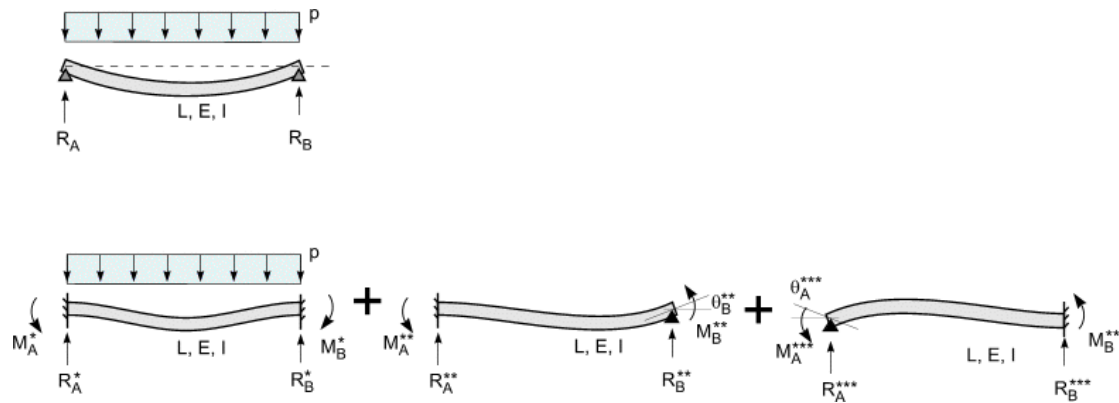

54. Describe how you would solve the beam shown below by using the displacement method.

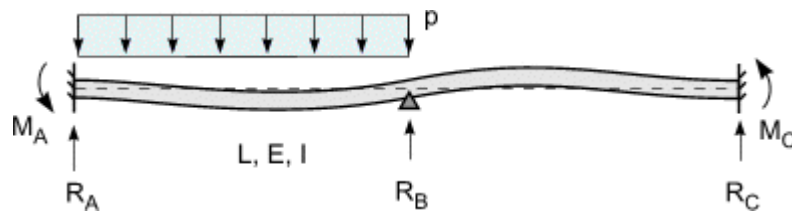

55. For the simple beam shown below, derive the shear stiffness terms (i.e k_{15} to k_{65})

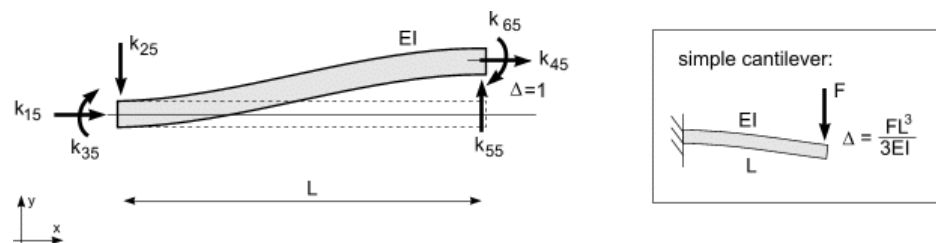

56. Solve the beam shown below using the stiffness method. Find the reactions at A and B, and the deflection at B.

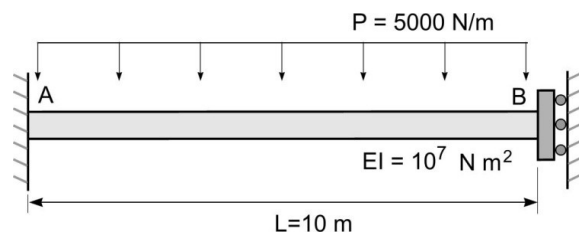

ANS: $M_A = 166667 \text{ N}\cdot\text{m}$, $M_B = 83333 \text{ N}\cdot\text{m}$ $\Delta_B = -.2082 \text{ m}$

57. Stiffness method .

sketch a 2D beam and show the degrees of freedom.

Describe the meaning of the terms (any, all) in the 6x6 stiffness matrix for a 2D beam, and give 2 examples.

58. Explain the difference between the “Force” method, and the “Displacement” method.

59. In the stiffness method for a 2D beam, the standard value for the k_{22} stiffness term is;

$$k_{22} = 12 \frac{EI}{L^3}$$

Derive this equation (Table 1 in appendix may be useful).

Chapter 12: Energy Methods in Structural Analysis

60. Find the location of the force F so that θ is a maximum. Hint: you can use the symmetry of Betti-Maxwell.

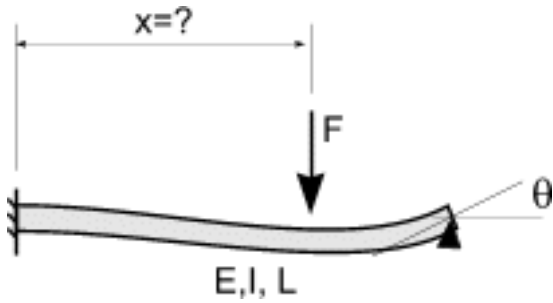

61. Illustrate the Betti-Maxwell theorem using the beam load cases shown below. Use the deflection table on pg 8 at the end of the paper.

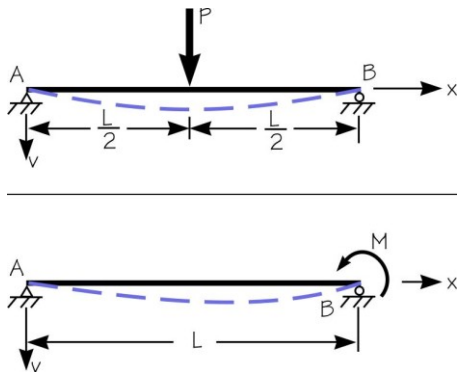

Chapter 13: The Moment Distribution Method

62. Moment distribution method

Solve the attached indeterminate beam problem by the Moment Distribution Method. Complete 2 cycles of the solution.

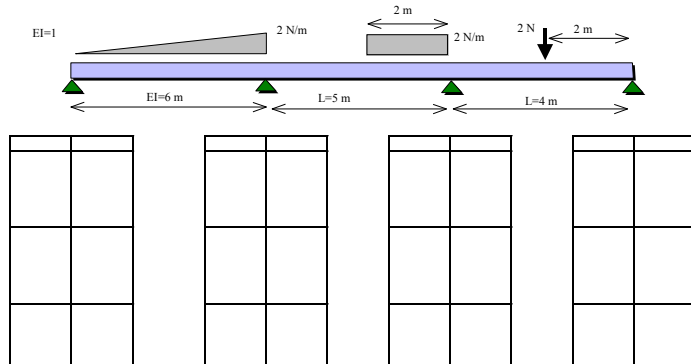

63. Moment distribution method

Solve the attached indeterminate beam problem by the Moment Distribution Method. Complete 2 cycles of the solution.

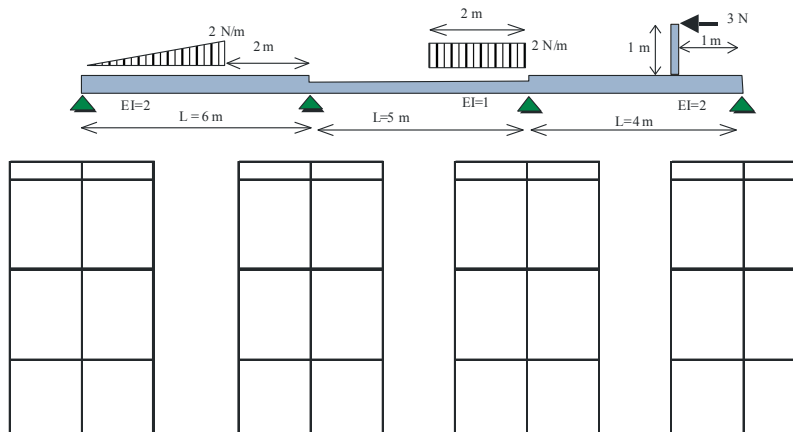

64. Moment distribution method. For the case shown on the attached page (Figure 1), fill in the first two cycles of the MD calculations.

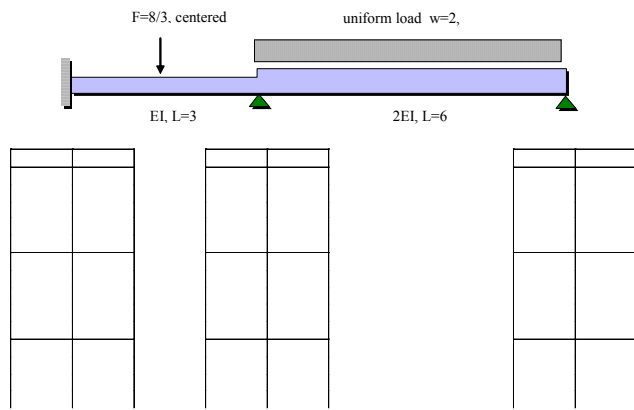

(13)

Chapt. 12 Problems

1. Solve the beam by the Moment Distribution Method.

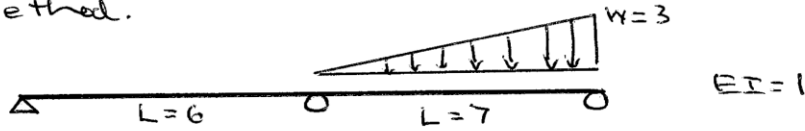

2. Solve the beam by the Moment Distribution Method.

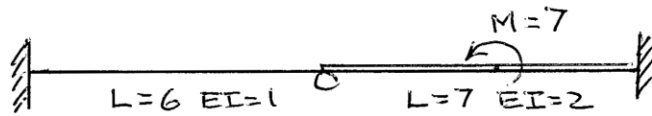

3. Solve this frame by the Moment Distribution Method.

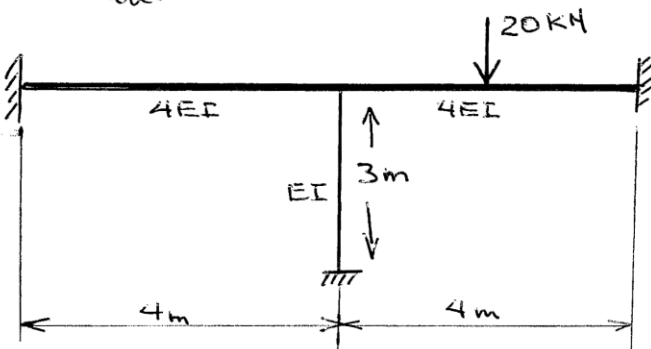

65. For the statically indeterminate beam shown below, with the loads, properties and end conditions as given,

- Solve using the moment distribution method.
- What is the vertical reaction at the middle support

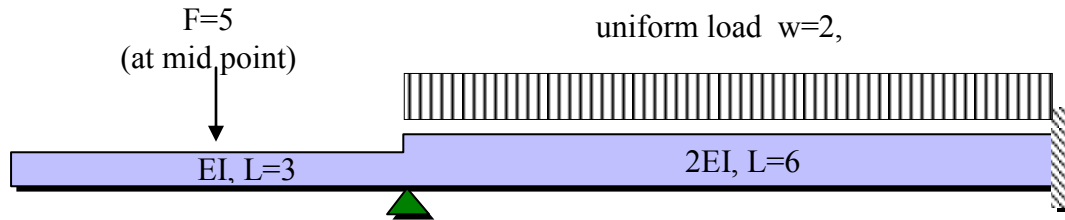

66. A 3 bar frame is shown below.

Solve for the moments using the moment distribution method.

Sketch the deformed shape.

Find the vertical reaction at the pin (the right hand end).

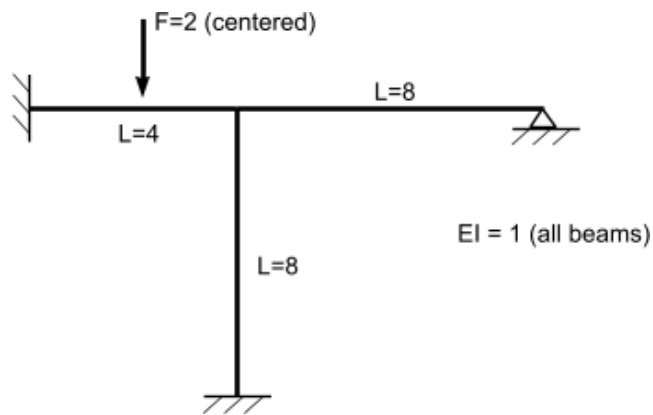

67. Solve the frame using the MDM method (suggest you use a spreadsheet).

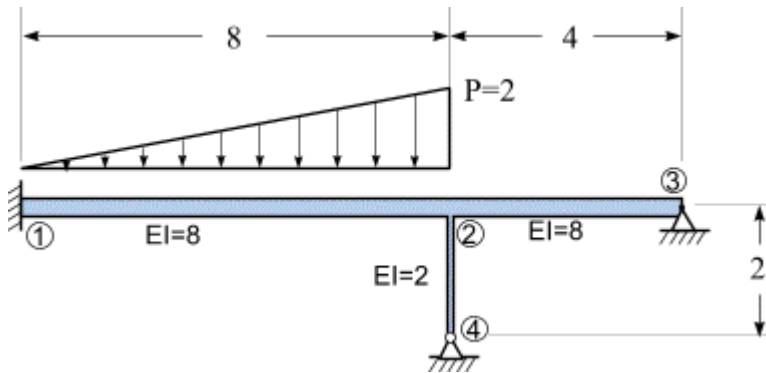

68. Solve the frame using the MDM method (suggest you use a spreadsheet).

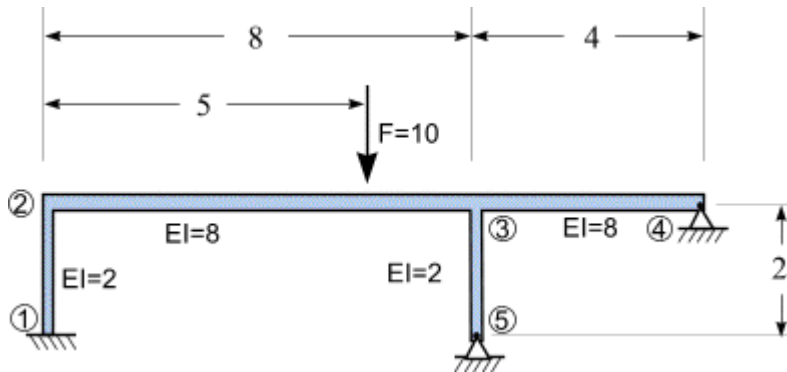

69. For the case shown below, set up and fill in the first two cycles of the Moment Distribution calculations.

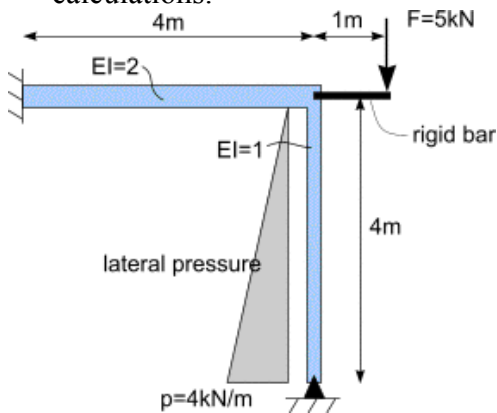

70. A 2 bar structure is shown below.
- Solve for the moments using the moment distribution method.
 - Find the vertical reaction at the pin A (the left).

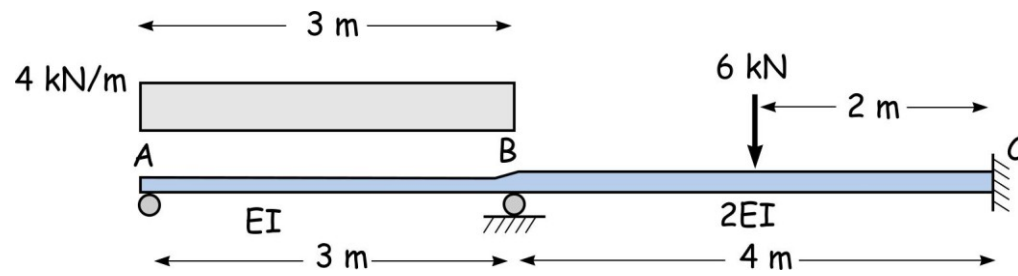

Chapter 14: The Moment Distribution Method with Sway

71. Solve the frame using the MDM method (suggest you use a spreadsheet).

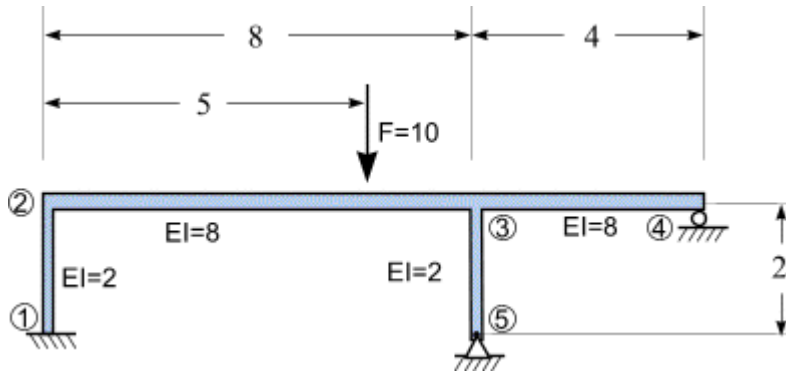

72. A 3 bar frame is shown below.

Solve for the moments using the moment distribution method.

Sketch the deformed shape.

Find the vertical reaction at the pin (the right hand end).

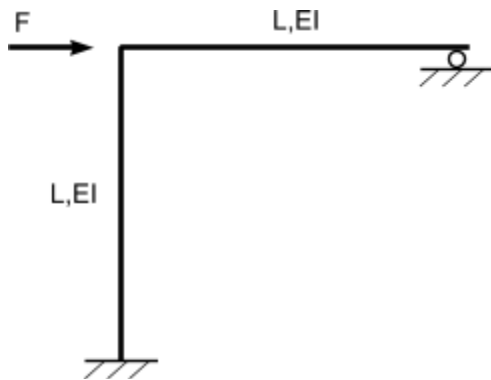

Chapter 15: Matrix Structural Analysis

73. Frame Structures can be analyzed by "Matrix Structural Analysis" or by solution of sets of continuous differential equations. Compare and contrast these two approaches.
74. The stiffness matrix for a 2D beam is said to have axial, shear and rotary terms. Give examples of each of the 3 types of stiffness (i.e. 3 examples of the individual k_{ij} terms), with a sketch of the terms.
75. Describe what is meant by the "rotary stiffness terms" in the stiffness matrix of a beam. Explain which terms in the matrix are rotary terms and how they are derived.
76. For the 4-bar frame shown below, the 2D solution is found by solving 12 equations in matrix form shown beneath. For the case of the loads and boundary conditions as shown, fill in the 14 columns (there is 1 column for forces, 1 for displacements and 12 in the stiffness matrix), with any known values. In the force and displacement vectors, write in a zero (0) for known zero values and the letter X or variable name for other unknown values. In the stiffness matrix write a 0 for the zero terms and the letter K for a non-zero stiffness terms. You only need to fill in the upper half of the stiffness matrix. You don't need any equations or numbers (other than 0).

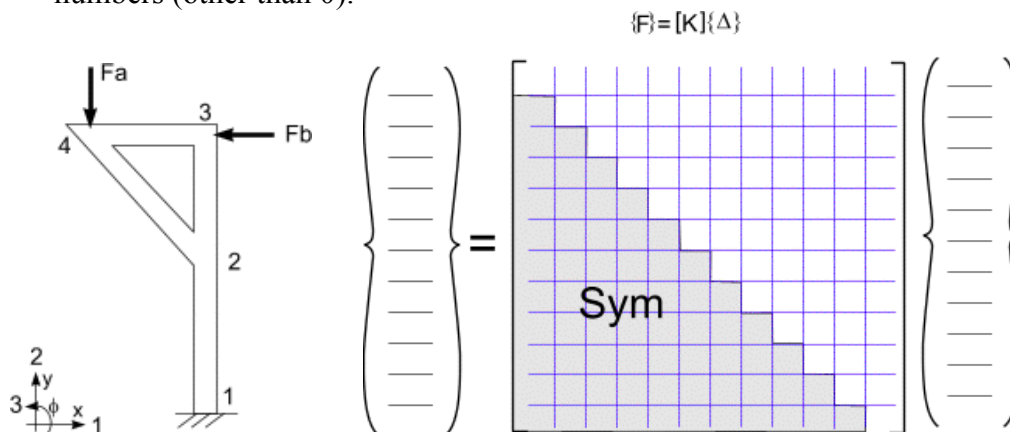

77. A 2 part frame is shown below.
- Construct the full structural stiffness matrix for the structure. Describe the steps you take to do so. (12)
 - Write the force-deflection equation for the structure in matrix format, showing all terms (ie include all terms in the matrices or vectors). Explain which, if any, terms are unknown. (8)

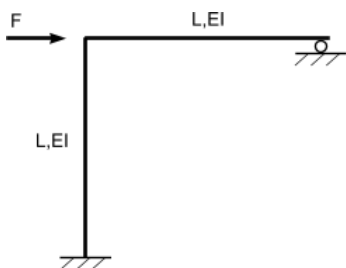

78. Assuming that you are using a program that performs matrix structural analysis, explain concisely how the global stiffness terms for the joint circled in the sketch below are determined. You don't have to solve this frame.

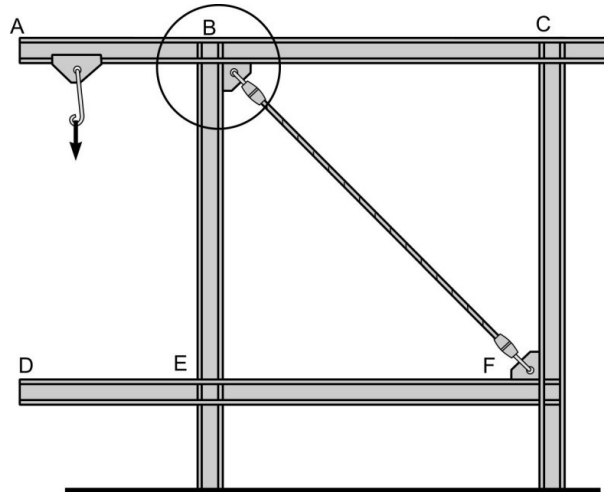

Chapter 16 Overview of Finite Element Theory

79. The displacement functions of the constant stress triangular element are:

$$u(x,y) = C1 + C2 x + C3 y$$

$$v(x,y) = C4 + C5 x + C6 y$$

where u represents the x -translation of any point (x,y) and v represents the y -translation of the point.

A beam has only one coordinate (x). However, most beam models would allow a point on the beam to rotate as well as translate. So, construct 3 simple displacement functions;

$$u(x),$$

$$v(x),$$

$$\theta(x),$$

of a 'beam element', using the same logic as was used to create the displacement functions of the constant stress triangular element.

Discuss the differences between this approach Chapter 16 – Problems

Chapter 17: Hull Girder Shear Stresses

80. An open section is shown below. This is the cross section of a long folded steel plate. The cross section is subject to a shear force of 2 MN

Solve the shear flow, plot it and then also show the shear stress values. (10)

If this is a section of a long cantilever (fixed at one end and free at the other) explain what types of deformations would you expect to see. (5)

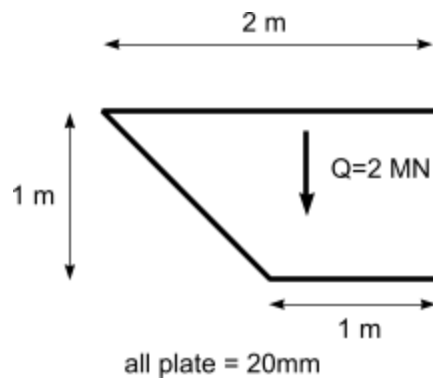

81. An open section is shown below. This is the cross section of transverse frame in a ship. The shear force of 200 kN

- Solve the shear flow, plot it and then also show the shear stress values. (10)
- The web is welded to the shell plate. What shear force must be resisted at this joint? (5)

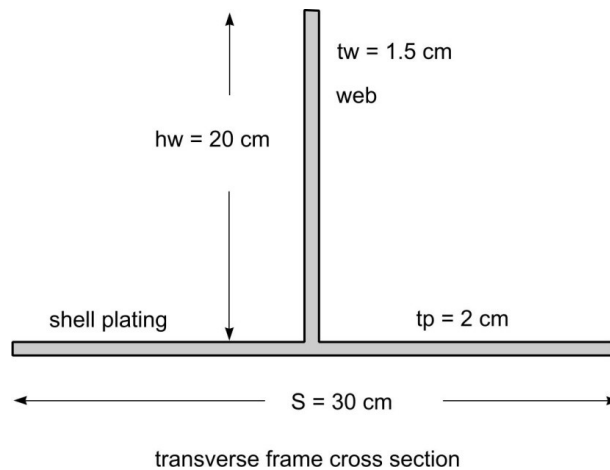

Chapter 18: Shear Stresses in multi-cell sections

82. Solve the shear flow in the following section of a tanker. Ignore the radius of the bilge.

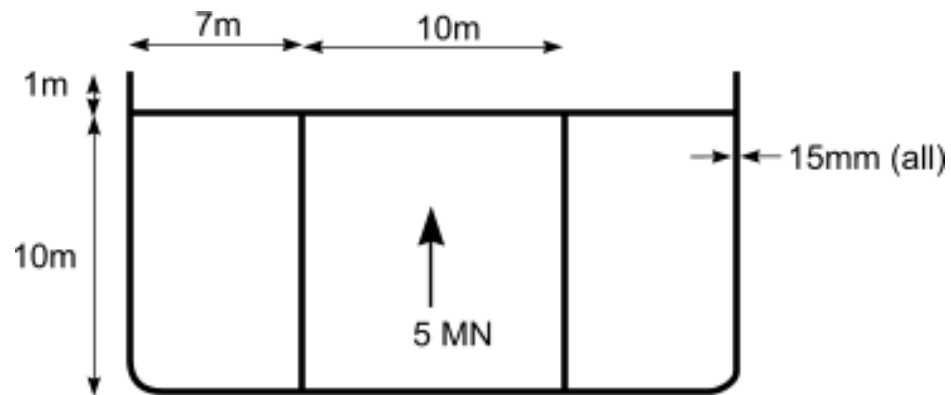

Chapter 19: Shear Flow in adjacent Closed Cells

83. Solve the shear flow in the following section of a tanker. Ignore the radius of the bilge.

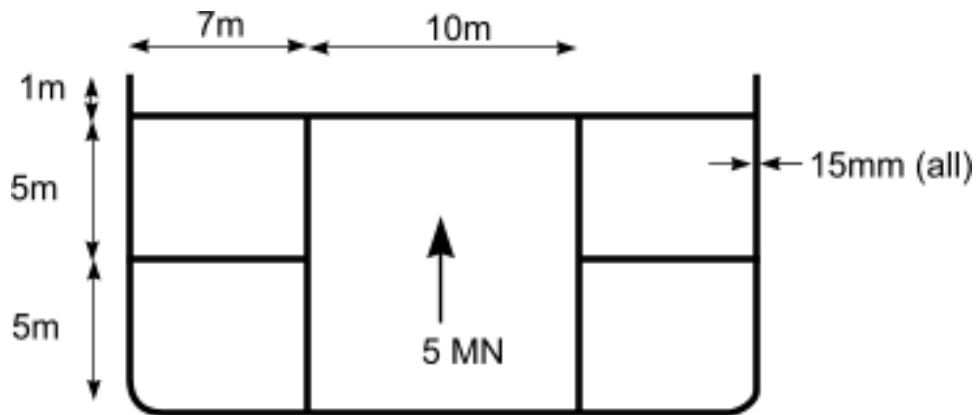

Chapter 20: Torsion in ships

84. A hollow closed section is made of plate of uniform thickness 't'. A torsional moment of 80 MN-m is applied. To have the maximum shear stress equal to 135 MPa, what value should t be ?

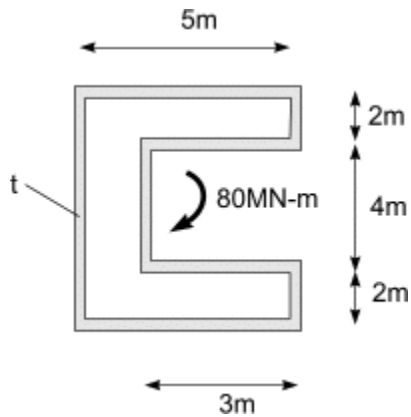

Chapter 21: Shear Center and Shear Lag in Ship Structures

85. The following figure shows 4 x-sections. Identify the location of the shear center in each case (i.e which letter?). You should sketch the shear flow to help identify the location.

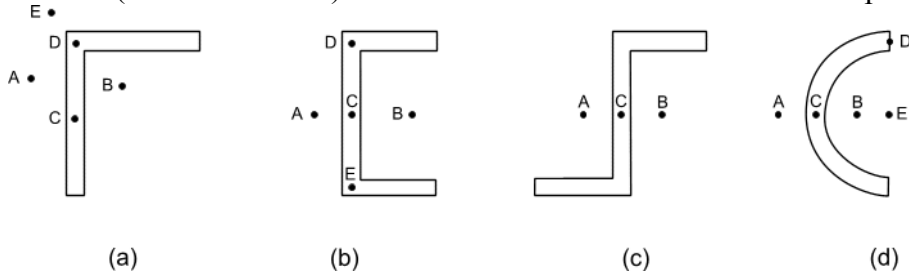

86. When the vertical force F is applied to this section, how will the cantilever beam deform? Explain

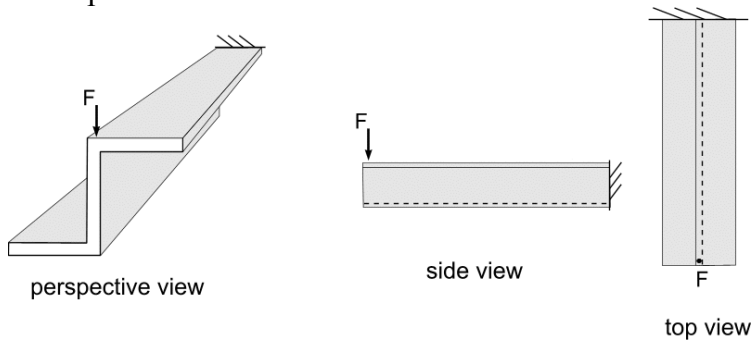

Chapter 22: Plate Bending

Chapter 23: Hull Girder Stress Assessment

87. Ship strength (indicate if true or false, and provide an explanatory comment)

[T,F]

a) structural design determines the principal dimensions of a ship.	
comment:	
b) The only static loads are those that result from gravity.	
comment:	
c) All forces on a ship are in balance, unless there are large waves.	
comment:	
d) Shell plating is called 'primary structure'.	
comment:	
e) Simple beam theory ignores shear stresses.	
comment:	
f) Murray's Method is a quick way to obtain wave bending moments.	
comment:	
g) The Prohaska method is used to estimate buoyancy.	
comment:	
h) The Moment distribution method will not work if the structure is indeterminate.	
comment:	
i) Trochoidal waves have relatively steep crests and shallow troughs.	
comment:	
i) A tee stiffener is an open section.	
comment:	

Appendix

Formulae

Weight of a Vessel:

$$W = \Delta = C_B \cdot L \cdot B \cdot T \cdot \gamma$$

Prohaska for parallel middle body : $\bar{W} = \frac{W_{hull}}{L}$ the values of a and b are ;

	$\frac{a}{\bar{W}}$	$\frac{b}{\bar{W}}$
Tankers ($C_B = .85$)	.75	1.125
Full Cargo Ships ($C_B = .8$)	.55	1.225
Fine Cargo Ships ($C_B = .65$)	.45	1.275
Large Passenger Ships ($C_B = .55$)	.30	1.35

$$\Delta lcg = \frac{x}{\bar{W}} L \frac{7}{54}$$

Murray's Method

$$BM_B = \frac{1}{2} (\Delta_a g_a + \Delta_f g_f) = \frac{1}{2} \Delta \cdot \bar{x}$$

$$\bar{x} = L(a \cdot C_B + b)$$

Where

T/L	a	b
.03	.209	.03
.04	.199	.041
.05	.189	.052
.06	.179	.063

This table for a and b can be represented adequately by the equation;

$$a = .239 - T/L$$

$$b = 1.1 T/L - .003$$

Trochoidal Wave Profile

$$x = R\theta - r \sin \theta \quad \theta = \text{rolling angle}$$

$$z = r(1 - \cos \theta)$$

Section Modulus Calculations

$$I_{na} = 1/12 a d^2$$

$$= 1/12 t b^3 \cos^2 \theta$$

Family of Differential Equations Beam Bending

$$v = \text{deflection [m]}$$

$$v' = \theta = \text{slope [rad]}$$

$$v''EI = M = \text{bending moment [N-m]}$$

$$v'''EI = Q = \text{shear force [N]}$$

$$v''''EI = P = \text{line load [N/m]}$$

Stiffness Terms

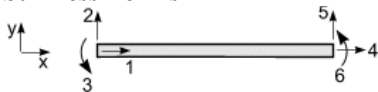

2D beam = 6 degrees of freedom

$$K = \begin{bmatrix} \frac{AE}{L} & 0 & 0 & -\frac{AE}{L} & 0 & 0 \\ 0 & \frac{12EI}{L^3} & \frac{6EI}{L^2} & 0 & -\frac{12EI}{L^3} & \frac{6EI}{L^2} \\ 0 & \frac{6EI}{L^2} & \frac{4EI}{L} & 0 & -\frac{6EI}{L^2} & \frac{2EI}{L} \\ -\frac{AE}{L} & 0 & 0 & \frac{AE}{L} & 0 & 0 \\ 0 & -\frac{12EI}{L^3} & -\frac{6EI}{L^2} & 0 & \frac{12EI}{L^3} & -\frac{6EI}{L^2} \\ 0 & \frac{6EI}{L^2} & \frac{2EI}{L} & 0 & -\frac{6EI}{L^2} & \frac{4EI}{L} \end{bmatrix}$$

Shear flow: $q = \tau t$, $q = Q m / I$
 $m = \int y t ds$

Fixed End Moments

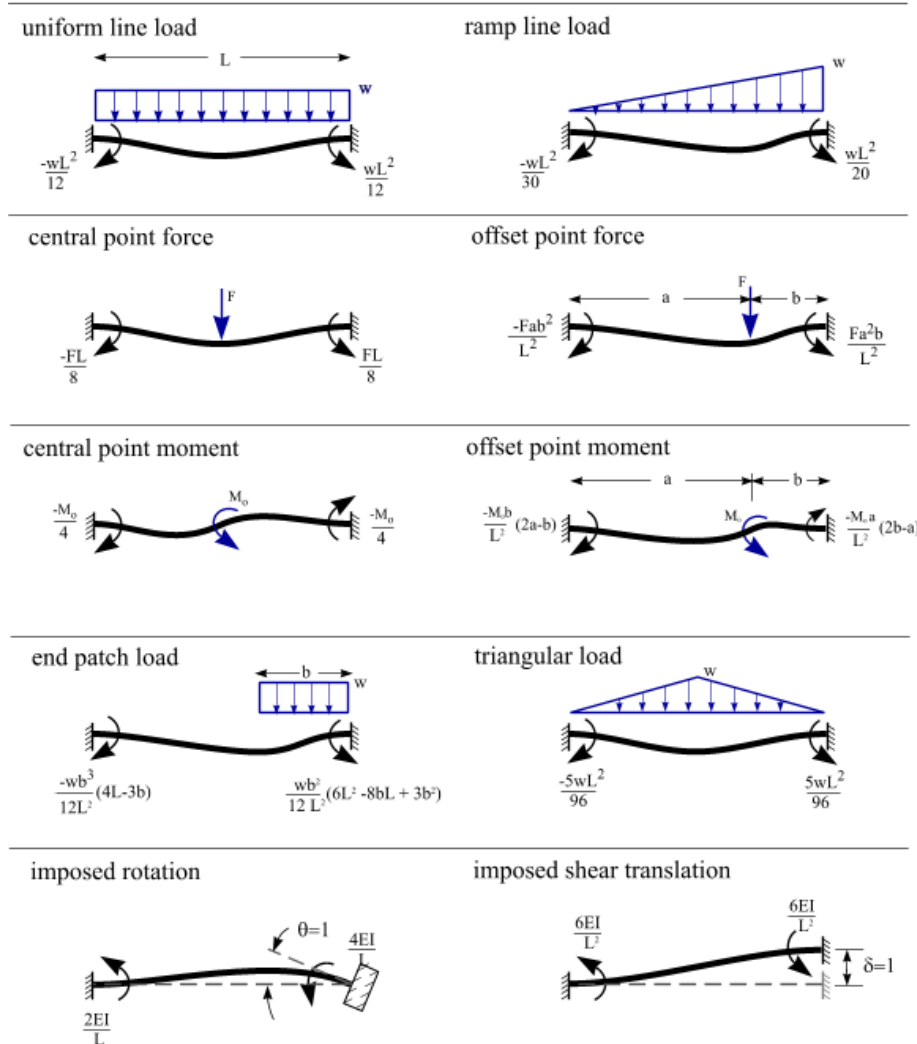
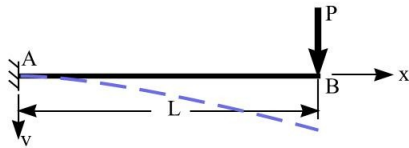
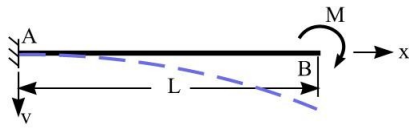
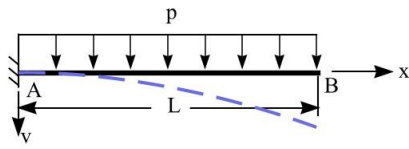
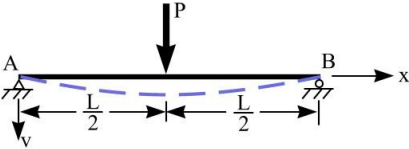
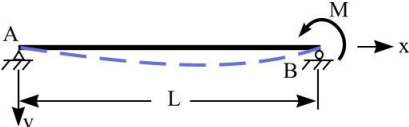
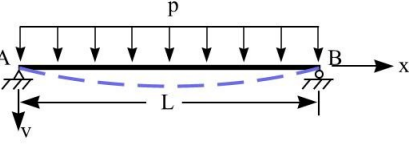
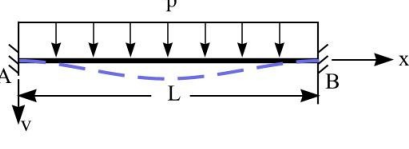
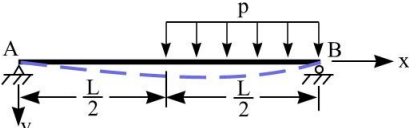

Table 1 Deflection and Slopes of Beams

Loading	Deflection	Slope
	$v = \frac{Px^2}{6EI} (3L - x)$ $v_{max} = v_B = \frac{PL^3}{3EI}$	$\theta_B = \frac{PL^2}{2EI}$
	$v = \frac{Mx^2}{2EI}$ $v_{max} = v_B = \frac{ML^2}{2EI}$	$\theta_B = \frac{ML}{EI}$
	$v = \frac{px^2}{24EI} (6L^2 - 4Lx + x^2)$ $v_{max} = v_B = \frac{pL^4}{8EI}$	$\theta_B = \frac{pL^3}{6EI}$
	$v = \frac{Px^2}{48EI} (3L^2 - 4x^2)$ $v_{max} = \frac{PL^3}{48EI} \text{ @ } x=L/2$	$\theta_A = -\theta_B = \frac{PL^2}{16EI}$
	$v = \frac{Mx}{6EI} (L^2 - x^2)$ $v_{max} = \frac{ML^2}{9\sqrt{3}EI} \text{ @ } x=L/\sqrt{3}$	$\theta_A = \frac{ML}{8EI}$ $\theta_B = -\frac{ML}{3EI}$
	$v = \frac{px}{24EI} (L^3 - 2Lx^2 + x^3)$ $v_{max} = \frac{5pL^4}{384EI} \text{ @ } x=L/2$	$\theta_A = -\theta_B = \frac{pL^3}{24EI}$
	$v = \frac{px^2}{24EI} (L - x)^2$ $v_{max} = \frac{pL^4}{384EI} \text{ @ } x=L/2$	$\theta_A = \theta_B = 0$
	$v_{cent} = \frac{3pL^4}{256EI} \text{ @ } x=L/2$	$\theta_A = \frac{3pL^3}{128EI}$ $\theta_B = \frac{-pL^3}{12EI}$