

Engineering 4862 Microprocessors

Lecture 26

Cheng Li

EN-4012

licheng@engr.mun.ca

Interface ADC and Sensors to a PC

- AD558 is configured as “write only”
 - VCC range +4.5V ~ + 16.5 V, normally +5V
 - Vout Range: 0 ~ 2.56 V, or 0 ~ 10 V
 - Digital Input Code Output Voltage
- | Binary | Hex | Decimal | 2.56V | 10V |
|----------|-----|---------|--------|--------|
| 00000000 | 00 | 0 | 0 | 0 |
| 00000001 | 01 | 1 | 0.010V | 0.039V |
| 00001111 | 0F | 15 | 0.150V | 0.586V |
| 11111111 | FF | 255 | 2.55V | 9.961V |

Engr 4862 Microprocessors

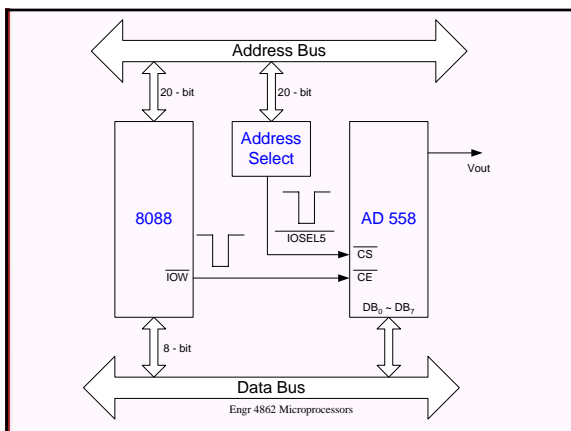

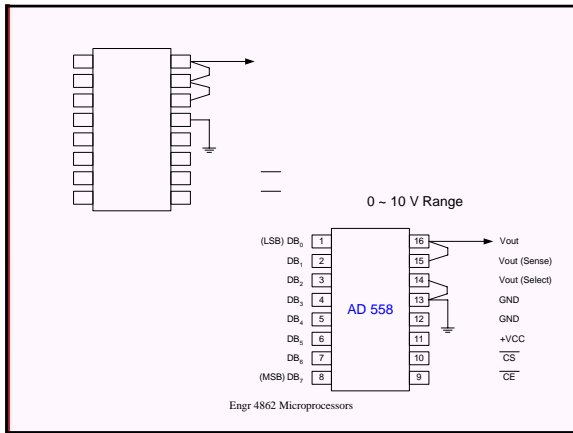

Interface ADC and Sensors to a PC

- ADC (Analog-to-Digital Converter)
 - Most widely used device for data acquisition
 - ADC converts the analog input to its binary equivalent and holds it in an internal register
 - Transducers: device that convert physical quantity to electrical signals, also called sensors
 - For ADC, in addition to resolution, conversion time (the time it takes the ADC to convert the analog input to a digital number), is another major factor in judging an ADC

Engr 4862 Microprocessors

DB₃
DB₄

0 ~ 2.56 V Range

1	16	Vout
2	15	Vout (Sense)
3	14	Vout (Select)
4	13	GND
5	12	GND
6	11	+VCC
7	10	CS
8	9	CE

AD 558

Pin Description

- \overline{RD} : active low input signal
 - \overline{RD} is used to get the converted data out of the chip
 - When $\overline{CS} = 0$, if a high-to-low pulse is applied to the \overline{RD} pin, the 8-bit digital output shows up at the D0 – D7 data pins
 - Thus, \overline{RD} is also referred to as output enable
- \overline{WR} : active low input signal → Start Conversion
 - If $\overline{CS} = 0$, when \overline{WR} makes a low-to-high transition, the ADC 804 starts converting the analog input value to an 8-bit digit number

Engr 4862 Microprocessors

Data Conversion Procedure

- Steps for data conversion by the AD804 chip
 - Make $\overline{CS} = 0$ and send a low-to-high pulse to the WR pin to start the conversion
 - Keep monitoring the INTR pin. If INTR is low, the conversion is finished and we can go to the next step. If the INTR is high, keep polling until it goes low
 - After INTR become low, we make $\overline{CS} = 0$ and send a high-to-low pulse to the RD pin to get the data out of the AD804 chip
 - Example1: AD804, Example2: AD7574

Engr 4862 Microprocessors

Methods of Address Decoding

- The CPU provides the address of the data desired, it is the job of the decoding circuitry to locate the data
- In connecting a memory chip to the CPU
 - The data bus is connected directly to memory data pins
 - Control signals MEMR and MEMW are connected to the RD and WR pins of the memory chip
 - For address busses, the lower bits of the address go directly to the memory chip address pins, the upper ones are used to activate the CS pin of the memory chip.
 - No data can be written into or read from the memory chip unless the CS is activated. CS is normally active low.

Engr 4862 Microprocessors

Decoding Methods

- Simple logical gate as address decoder
 - Use NAND or other gates because the output of NAND gate is active low and that is CS is also active low
 - In the case that the CS input is active high, and AND gate must be used
 - Using a combination of NAND and inverters, one can decode any address range
 - For example:
 - What's the memory chip address range?

Engr 4862 Microprocessors

Decoding Methods

– Use 74LS138 Decoder

- This is one of the most widely used address decoders
- The 3 pins A, B, C generate 8 active low output $Y_0 \sim Y_7$
- Each Y_x output is connected to CS of a memory chip, allowing control of 8 memory blocks by a single decoder
- In 74LS138, there are additional inputs, $\overline{G2A}$, $\overline{G2B}$, and G1. $\overline{G2A}$ and $\overline{G2B}$ are both active low, and G1 is active high. If any one of the inputs $\overline{G2A}$, $\overline{G2B}$, and G1 is not connected to an address signal, they must be activated permanently either by Vcc or Gnd.
- Example: give the range for the memory chip

Engr 4862 Microprocessors
