



LABORATORY INDENTATION TESTS SIMULATING ICE- STRUCTURE INTERACTIONS USING CONE-SHAPED ICE SAMPLES AND STEEL PLATES

Bruneau,S.¹, Colbourne,B.¹, Dragt,R.², Dillenburg,A.³, Ritter,S.³, Pilling,M.¹, Sullivan,A.¹

¹Memorial University of Newfoundland, STePS² Research Program

²Delft University of Technology, Delft, THE NETHERLANDS

³and.-Ing. University of Duisburg-Essen, Germany

ABSTRACT

This paper describes the results of a series of tests from 2010-2012 in which cone-shaped ice samples were crushed into steel indenters. Previous work by the authors described the sample production techniques and testing procedures, this paper describes the cumulative results from all tests to date (in excess of 150) in which cone angle, indentation rate, ice type and temperature, and indenter roughness were varied.

All ice-cone samples were right angled, circular pyramids with an opening angle varying between 100 and 180 degrees (flat-topped) projecting from a steel retaining ring 259 mm in diameter. Indentation rate was constant for individual tests and rates between 0.01 mm/s – 100 mm/s were examined along with a series of collision tests involving closing speeds over 1500m/s. Ice was produced using distilled and chilled water, un-seeded and seeded with ice seeds ranging in size from snow particles to 3cm cubes, frozen at various rates and tested at temperatures between 0 and -30 degrees Celsius. Additionally, saltwater was frozen and tested as was natural iceberg ice harvested and placed in the steel retaining ring for testing. The indenter surface remained flat and perpendicular for all tests; however, three values of surface roughness (0.13, 0.47 and 500 micrometers) were examined over a range of indentation speeds.

All data have been reduced to instantaneous force and crushing energy as a function of cone penetration and nominal volume. Trends are determined indicating the nature of load sensitivity to the control parameters. The transition from ductile to brittle behaviour is identified and mechanical processes are discussed.

INTRODUCTION

The STePS² program involves laboratory experimental work that is intended to provide calibration input for new numerical techniques modelling collisions between ships and ice. The experiments have been designed to provide reliable measurements of plausible but idealized ice structure interactions, indicative of full scale scenarios and consequently useful for predictive model development. Within STePS² it was suggested that a standardized approach to modelling collisions be developed so as to establish material and structural benchmarks – from which the significance/influence of some or many dependant variables may be measured. The idealized collision scenario thus established involves a flat steel plate colliding with a free-surface conical ice sample protruding from a steel retaining ring (Figure 1). The closing speed and penetration rate is controlled – usually constant, the plate remains perpendicular to the right axis of the cone and the final indentation is usually predetermined.

This test “platform” enabled incremental, instantaneous and complete observation and measurement of failure mechanics including interaction forces, pressures, crack formation and spalling behaviours. In a few pilot tests temperature changes were also examined using thermal imagery techniques.

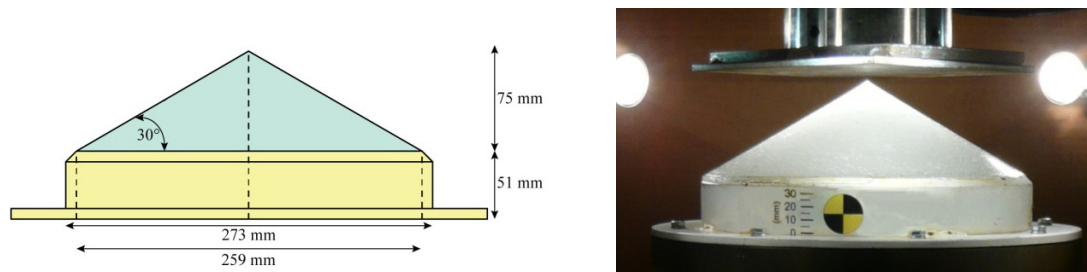

Figure 1. Schematic and image of typical ice cone sample in steel retaining ring

Typical control variables for this standardized collision test scenario were ice sample type, ice temperature, interaction rate, penetration depth, cone angle and plate roughness (Bruneau, Dillenburg and Ritter, 2011, 2012, Sullivan and Pilling, 2011, Dillenburg, 2012, Clarke, 2012, Dragt, 2013). Ice sample shapes other than right circular cones and steel indenters that are non-rigid and non-flat have also been investigated but are not reported in this work. In addition larger cone samples with base diameter of 1m have been tested in the STePS² program (e.g. Reddy et al. 2012) but are not reported here. The ranges of experimental parameters that are discussed in this paper are listed below in Table 1.

Table 1. Range of parameters captures in cone tests from 2010-2012

Parameter	Range
Ice Types	Fresh, Saline, Iceberg, Laboratory (various seed sizes, methods)
Cone Angles	0, 15, 20, 25, 30, 35 degree deparure from base
Indentation rates	2000-1500, 100, 30, 10, 3, 1, 0.3, 0.1, 0.03, 0.01 mm/s
Temp of samples during test	-30, -20, -10, -5, 0 °C
Roughness of impact plate	Smooth, Medium, Rough ($R_A = 0.13\mu\text{m}$, $0.47\mu\text{m}$ & $500\mu\text{m}$) analogous to painted steel, scored steel and rough concrete

Two apparati have been used to simulate the collision process, an MTS load frame and a double armed pendulum (Figure 2a and 2b). The MTS machine permitted constant rate and fixed depth of penetration tests over the range of .001 mm/s to 100 mm/s while the pendulum by the action of drawing upwards both the ice sample on one arm and the indenter plate on the other – had freefall closing speeds of 1500 mm/s to 2000 mm/s and penetration depths which resulted naturally from the available collision energy rather than externally applied loads.

SUMMARY OF RESULTS AND ANALYSES

In collecting the data from multiple experiments, most conducted as part of student research theses, our first task was in evaluating the consistency of the data gathered on a nominally common basis by a group of more-or-less independent researchers. Following this we looked for trends in, and sensitivity of, output data to the experimental control parameters listed in Table 1. One of our primary interests throughout this work was the identification of one or more measures that would provide the most unambiguous measure of ice resistance to crushing, either in the form of a peak supported load or a progressive pressure relationship or in some measure of energy consumed in the crushing. In addition we were interested to see

how the crushing rate effect for cone-shaped samples compared in either of these measures to more conventional published data for ice across the range of individually collected data sets.

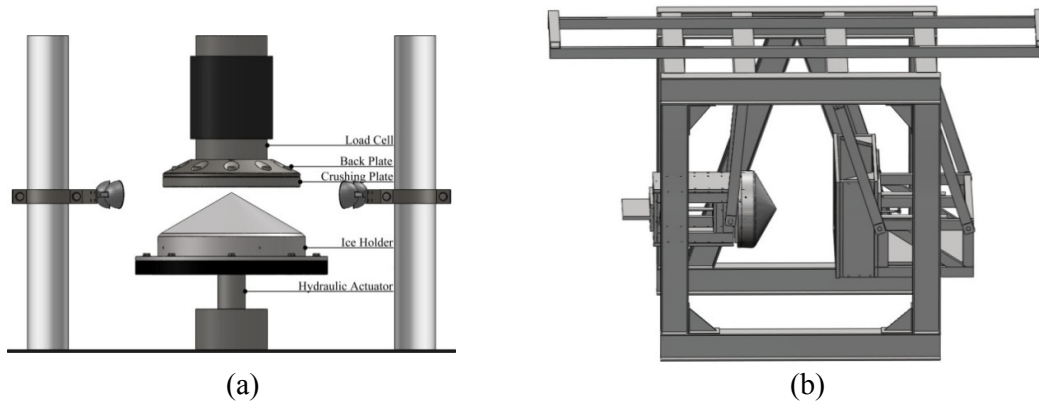

Figure 2. Schematic of MTS load frame (a) and double armed pendulum (b)

Crushing energy versus spall weight and peak force for all ice types

Earlier work (Bruneau, Dillenburg and Ritter, 2011, 2012, Sullivan and Pilling 2011, Dragt and Bruneau, 2013) examined the influence of ice manufacturing processes in order to develop both an acceptable and robust standard model and also to determine the extent to which ice type affected experimental results. Figure 3 presents a consolidation of relevant tests in this area and shows the variation of crushing energy per nominal volume as a function of spall weight (a) and peak force (b) for various types of manufactured ice. Detailed discussion of the sample making techniques and resultant ice morphologies are presented in the earlier works cited. Note that the terminology and rationale supporting the use of crushing energy and volume in the plots are discussed later in this paper. Crushing energy is calculated as the integration of the force-displacement curve to yield the effective work done by the testing machine in crushing the ice. In determining spall weight, crushed ice was collected after each test from a pan located under the ice specimen and by brushing the crushed ice off the specimen. This material was then transferred to a scale and weighed.

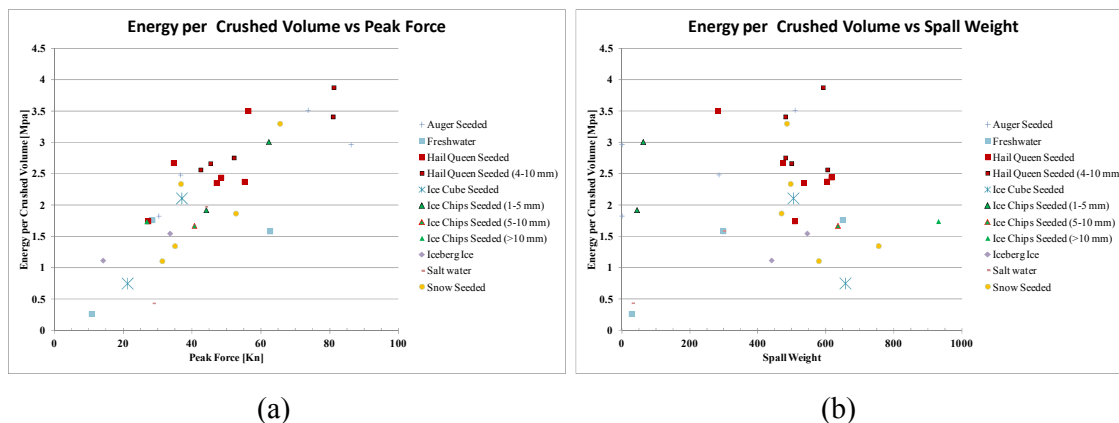

Figure 3. Consolidated results for crushing energy per unit volume versus (a) peak force, and (b) spall weight (in grams), of all ice types from relevant selected cone tests 2010-2012

Results indicate that samples prepared with saline ice had lower crushing strength (energy per crushed volume) though at salinity of 15 ppt the strength approached that of un-seeded

freshwater ice. In all cases there was considerably less spalling from saline samples than non-saline and the spalls tended to be wet in appearance. Generally, crushing strength increased with decreased seed size and spalling weight was somewhat proportional to seed size so that large seeds resulted in large spalls comparable in size to, and sometimes aligned with, individual seeds. Samples produced using un-seeded freshwater were of lower crushing strength to those that were seeded. Thin section analysis of all sample types indicates a clear correlation between crystal size, strength and spalling. The smaller the seeds, the smaller the crystal and spall sizes and the greater the homogeneity and crushing strength.

Crushing energy versus cone angle and plate roughness

The slope of the cone and the roughness of the indenter plate were also examined with results indicated in Figure 4(a) and (b).

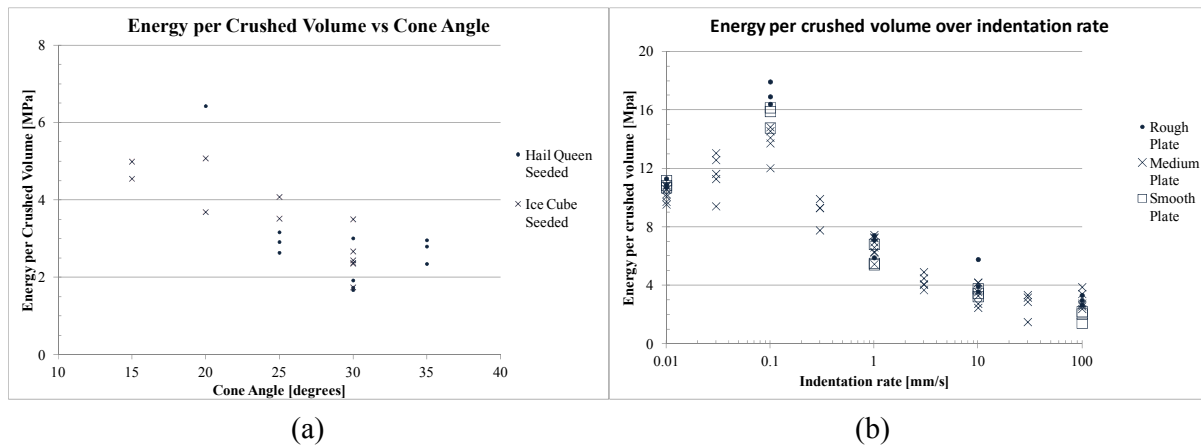

Figure 4. Consolidated results for crushing energy per unit volume versus (a) cone angle and (b) plate roughness from relevant selected results 2010-2012.

In this case we use the term tall to describe cones with lower included angles and steeper side slopes and we use the term shallow to describe the cones with higher included angles and shallower side slopes. In general we found that shallower cones supported higher loads and we believe this to be associated with confinement during the crushing event. Taller cones allowed spalled ice to fall away from the contact zone more easily than in the case of the shallower cones. We hypothesize that the greater difficulty in ejecting crushed material from the contact zone led to higher levels of ice confinement and this in turn supports higher pressures in the contact area. When the base of the cone was elevated from the steel retaining ring, in other words when there was a portion of the ice sample which remained cylindrical and unsupported extending from the steel retaining ring and from which the conical portion further extended, the effect of confinement was lost. In the extreme, one sample in the form of a free-standing cylinder projecting out from the steel retaining ring was crushed against the steel plate. The result was a catastrophic brittle failure of the cylinder after a mere 1.1mm penetration with a peak load of 21 kN occurring at that time, spalls removed the remaining ice extending from the ring was roughly cone-shaped not unlike the other samples tested.

The roughness effect was not so obvious. The smooth surface was a polished unpainted stainless steel surface. The rough surface was a stainless steel plate with a roughness grid specifically machined into the surface of the plate to provide the required roughness. The rougher plate, analogous to rough concrete ($R_A = 500\mu\text{m}$) as we expected, gave rise to higher

observed forces. This we also attribute to the restriction on extruding crushed material leading to higher confinement. However in a counter-intuitive observation, the very smooth plate ($R_A = 0.13\mu\text{m}$) also gave higher forces at lower indentation speeds. In these cases it was observed post-test that there was considerable ice that was adhered to the plate. We believe that this adhesion to the very smooth plate also led to higher levels of confinement. At very high loading rates results were mixed and all the test results fell within a comparable region. The medium plate representative of typical untreated steel had a roughness height of $R_A = 0.47\mu\text{m}$ and was the default surface for all other tests in the work described herein.

Crushing energy versus temperature

An examination of the effect of ice sample temperature on peak force and crushing energy was made using 30 degree cones indented at 100mm/s. The sample temperature influenced peak force in an inverse relation but crushing energy, between 2 and 3 MPa, was relatively insensitive as figures 5 (a) and (b) attest. A trend of higher spall weights for lower temperatures was observed, and the difficulties of handling the coldest of samples were noted. Further discussion of these results can be found in Bruneau et al. (2012).

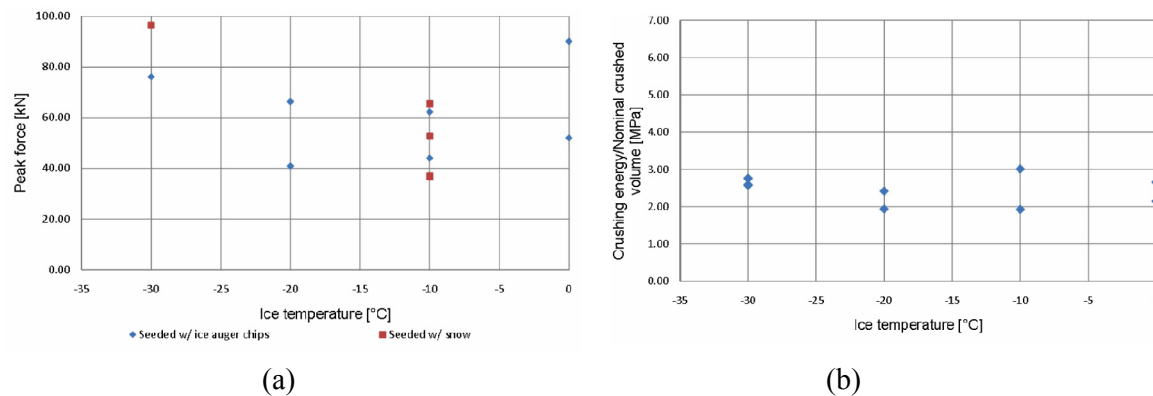

Figure 5. Results for (a) peak force versus sample temperature, and (b) crushing energy versus sample temperature, from Bruneau, Dillenburg and Ritter 2012.

The sensitivity of “strength” and fracture mechanics to some key control parameters has now been broadly described. This work serves to shoulder the selected conditions for our “standardized” test platform from which all further examinations of rate effects are made:

- Ice produced from ice seeds sieved from 4-10mm crushed cubes and flooded with distilled, degassed and deionised water, frozen then tested at a temperature of -10°C
- Cone angle of 30° produced by rotary-shaving cylinders into cones flush with the edge of a steel retaining ring
- Indenter roughness of $R_A = 0.47\mu\text{m}$ approximating unfinished slightly scored steel.

Crushing energy versus indentation rate

The simplest measure of ice loading is the measured force and in all the surveyed cases, force was recorded as the indentation progressed. Figure 6 shows a plot of the peak measured load against the loading rate for 259 mm diameter cone shaped samples with a 30° cone angle within the first 45mm of penetration.

This clearly shows a strong dependence on the loading rate. As a side note we determined that the use of the strain rate presented too many difficulties in terms of determining appropriate and repeatable values for strain given the cone shape so we used the loading rate which is

essentially the average velocity over the course of an impact of the indenter. For the MTS machine tests this rate remained constant but for the pendulum impact tests this velocity was not constant.

The second measure of interest was the progression of average pressure as the ice crushing or impact proceeded. Calculations of average pressure based on the measured force and the inferred average contact area were found almost universally for these experiments to fit a curve of the form:

$$P = P_0 A^{-c}$$

Where P is the calculated pressure defined as F/A , where F is the measured Force and A is the contact area calculated as the contact area of the crushed cone. Figure 7 is derived from a typical test and was produced by calculating the nominal contact area based on the circular disk area of the truncated cone at the depth of penetration. Given that the crushing force is measured as a function of penetration the pressure can be calculated as the measured force over the calculated contact area and then plotted against the calculated contact area to yield the data points in the figure. P_0 and C are constants, which varied from test to test. P_0 was observed to be dependent on various test parameters including loading rate, cone angle and the compliance of the impact surface. C also varied from test to test but could be reasonably approximated on average at 0.15 - 0.20. Tests were analyzed to derive the P_0 and the C values based on the test measurements up to the time of peak force. Given that the C values appeared to vary randomly and were reasonably grouped around the mean value, the P_0 value was used as the primary measure of ice crushing resistance.

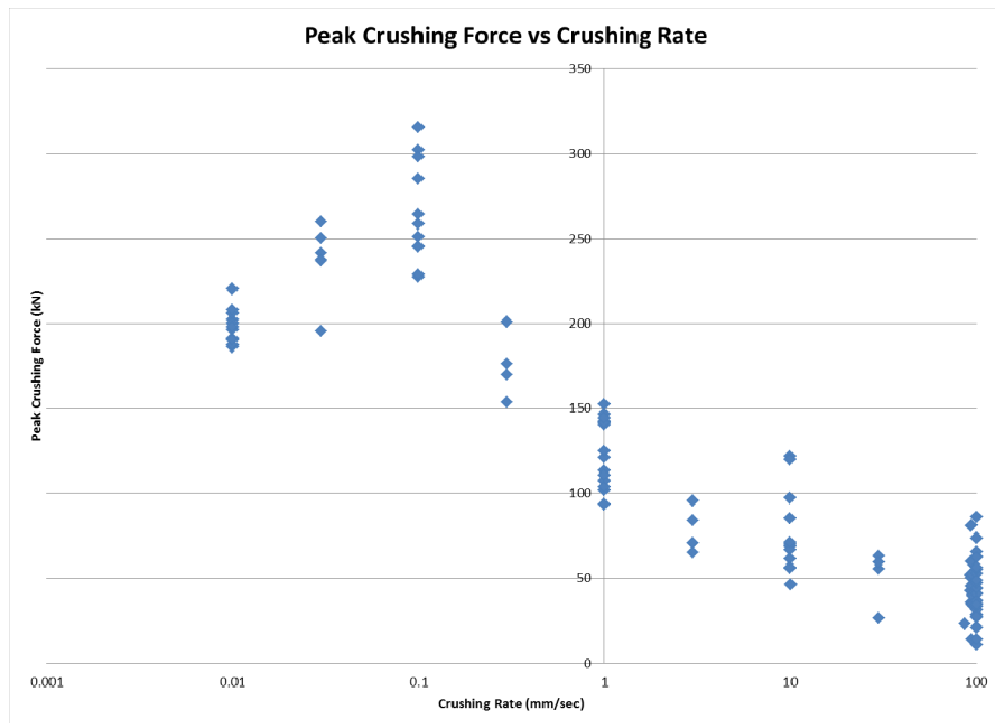

Figure 6. Peak measured crushing force plotted against crushing rate

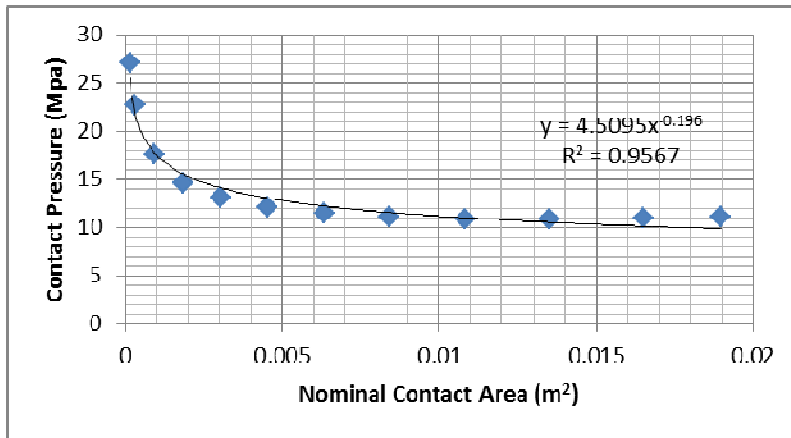

Figure 7. Typical Pressure versus contact area plot for ice cone tests in MTS machine

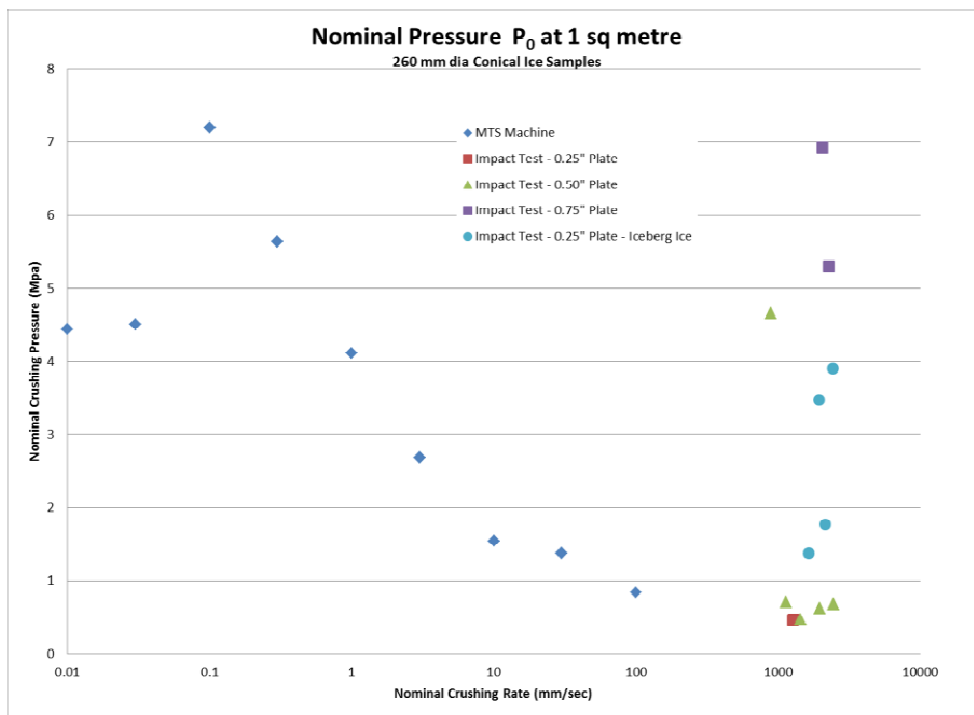

Figure 8. Peak nominal pressure P_0 plotted against crushing rate including data from pendulum impact tests

Values of the P_0 are plotted against loading rate in Figure 8 and show similar trends to the peak force. In both cases the data follows the normally observed increase in strength (by either measure) with increasing loading rate in the ductile range. However a pronounced peak is evident in the ductile-brittle transition region and there is a substantial drop in apparent strength for high rate brittle failures. This is a bit at odds with other data in that the drop in strength for high rates is more pronounced than generally observed. This may be a function of

the cone geometry. Although the tests using the hydraulic apparatus and those using the pendulum apparatus are probably not directly comparable, we used the pendulum impact data to extend our summary one order of magnitude further in loading rate. Of the pendulum tests, the most directly comparable are those that involved impacts with the stiffest plate. These provided the lowest level of compliance and this would be the closest case to the boundary condition of the MTS machine. These points are comparable in nominal pressure to the highest measured in the conventional tests. This indicates that we might expect a sharply increasing ice crushing resistance for very high loading rates. This is also consistent with other presented data in the literature. The remaining data for the pendulum impacts is also plotted and shows that less stiff structures give rise to lowered ice impact loads. However the data is somewhat scattered and will be further analysed.

The third evaluated measure was that of energy consumed per unit of crushed volume which also has units of Pressure. It was thought that this sort of volumetric averaging might allow some of the randomness in ice fracturing and spalling to be normalized. We thought that a measure of energy consumed on a volumetric average might provide a measure that is more adaptable to the irregular ice shapes that would be encountered in real-life ice interaction scenarios. This data is plotted in Figure 9 for two test temperatures, and shows similar trends in terms of loading rate but certainly no reduction in scatter.

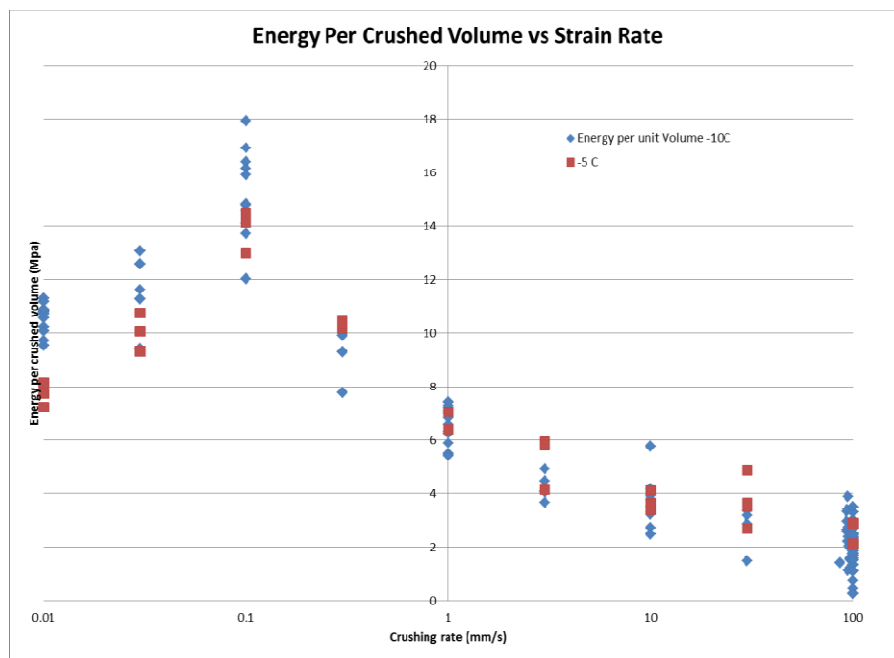

Figure 9. Energy per crushed volume plotted against crushing rate

To further explore the validity of the energy idea as a measure of ice strength for the cone shapes, we looked at a correlation between the specific energy (energy per volume of crushed ice) to the pressure measured at peak force and found the two measures to be very well correlated (Figure 10). This indicates that the energy measure is reliable in comparison to more conventional pressure measurement and that it might be used to assess the effective pressures of more irregular ice shapes in indentations with more realistic structures or in more complex experiments.

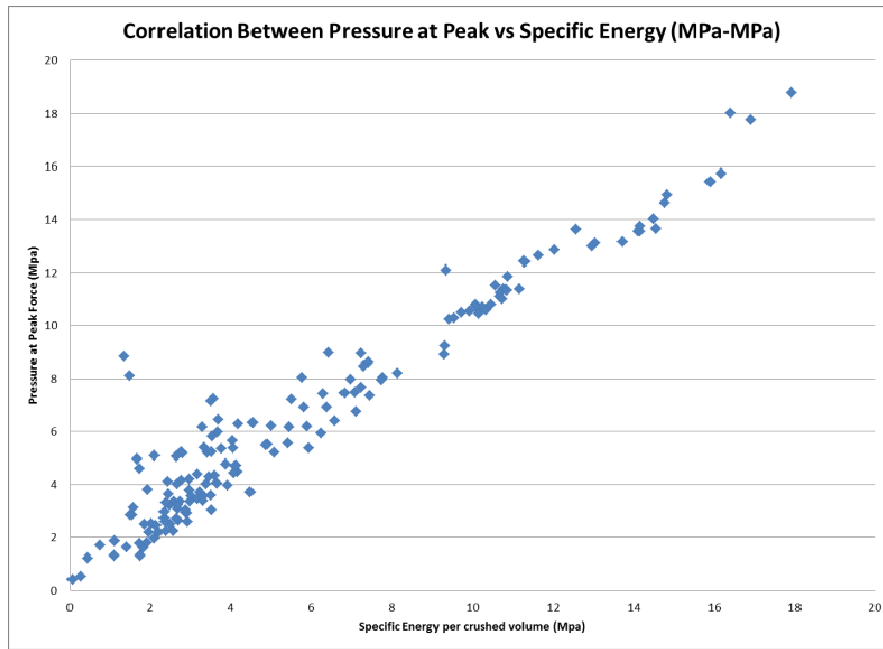

Figure 10. Correlation between pressure at peak force and specific energy

CONCLUSION

In summary, the crushing strength data derived from cone shaped ice samples shows similar trends in terms of loading (nominal strain) rate and in terms of pressure-area relationship to that reported for other sample types and indenters. This gives confidence that the cone shape offers us a consistent measure of ice strength in crushing and provides a more analogous crushing or impact scenario to real-life interactions. We plan to further explore the progression and distribution of pressures including the effects of confinement and spalling as work progresses. The progressive interaction that can be achieved using a cone shape allows some of these effects to be dealt with more directly in a given set of experiments that can be done with uniform section samples or large ice – small indenter scenarios.

In discussing some of the limitations of this data the most error prone aspect of the analysis appears to be the calculation of the contact area. Determination of the nominal contact area requires that we estimate the crushed radius of the interacting ice face. This was done based on the measured displacement of the indenter as a direct measurement of the contact face could not be obtained. This has obvious limitations as it requires an accurate determination of the starting point and it neglects any consideration of increases or decreases in contact area due to deformation or fracturing processes. Thus our area is an approximation.

We believe that some of the observed changes in apparent crushing pressure are related to issues of confinement and thus increasing local pressures within the contact area, commonly referred to as high pressure zones. Although we would like to discuss internal distributions of pressure within the crushing contact area further, this internal pressure was not measured in any of the tests covered in this work, and thus any such discussion would be speculation. This does however indicate a good direction for further investigation.

ACKNOWLEDGEMENTS

The authors would like to acknowledge the financial support of Atlantic Canada Opportunities Agency, Research and Development Corporation, American Bureau of Shipping, BMT Fleet Technology, Husky Energy, Rolls-Royce Marine, Samsung Heavy Industries and The National Research Council Canada.

REFERENCES

Bruneau, S., Dillenburg, A., Ritter, S. "Ice Specimen Fabrication Techniques and Indentation Experiments, A StePS² Pilot Laboratory Investigation of Ice-Structure Interaction" STEPS-RP001-2011, Memorial University of Newfoundland, Sustainable Technology for Polar Ships and Structures, St. John's, NL, Canada, April, 2011, P.139

Bruneau, S., Dillenburg, A., Ritter, S. "Ice Sample Production Techniques and Indentation Tests for Laboratory Experiments Simulating Ship Collisions with Ice" ISOPE 2012, Rhodes, Greece, June 2012

Dillenburg, A. "Rate Dependency in Conical Ice Indenter Failure" M.Eng. Thesis, September 2012 University of Duisburg-Essen, Germany

Dragt, R.C., Bruneau, S.E. "The Collision of Cone Shape Ice Samples against Steel Plates of Varying Surface Roughness", POAC'13, June 2013

Clarke, G. "Ice Collisions with a Pendulum Impact Apparatus", M.Eng. Thesis, October 2012 Memorial University of Newfoundland

Sullivan, A. Pilling, M. "Influence of Ice Shapes on Indentation Loads" Work Term Report for STePS² program, Memorial University Division Of Cooperative Engineering, Aug 2011

Reddy, P.S., Colbourne, B., Daley, C. Bruneau, S.E., Gagnon, R. "Strength and Pressure Profiles from Conical Ice Crushing Experiments" ICETECH Paper No. ICETECH12-132-RF, 2012.